

ATTITUDE/ORBIT SIMULATION TOOLS FOR DRAG-AUGMENTED DEORBING - THE DGNC PROJECT -

**F. Dalla Vedova, *L. Ottone, *R. Nogueron, **A. Rinalducci, **P. Simplicio*

*LuxSpace (LXS) with **ESA/ESTEC

ABSTRACT

The paper describes the work performed and results achieved by LuxSpace for the ESA-supported DGNC project.

DGNC stands for Dragsail GNC. It is a project aiming at identifying the best GNC solution to be proposed for satellite (debris) deorbiting thanks to Dragsails.

The proposed and investigated GNC options are : (1) no attitude control, (2a) active attitude control constantly maximizing the area exposed to drag, this with a flat Dragsail, and (2b) active attitude control constantly maximizing the area exposed to drag, this with a pyramidal Dragsail. All DGNC options are also compared to deorbiting with (remainings of) onboard propulsion.

In support to the DGNC system design and analyses, a GNC MIL i.e. a dedicated simulation tool has been created and validated within the ESA-supported GNCDE development environment. The paper describes also this LuxSpace's GNC MIL.

Index Terms— CleanSpace, DGNC, Dragsail, GNC, Sail, Simulator, DAS

1. INTRODUCTION

Since several years now concern has raised worldwide with respect to sustainable development of Space and in particular, to the limitation/removal of space debris.

For ESA (LEO) projects, the related Standard [ECSS-U-AS-10C] is now applicable, requiring that space debris shall be removed from the LEO Protected Region in a maximum of 25 years after their release.

For other European, non-ESA (LEO) projects like e.g. Universities cubesats, Development Teams are invited to devote the right attention to the concerns raised by the sustainable development of Space. The ongoing EU H2020 ReDSHIFT project promises to provide some guidelines in support of this.

1.1. Methods to Comply to the “25-years” Rule

Several methods can be considered (in LEO) to comply with this new rule:

- Set the (initial) mission altitude in order to ensure natural decay within the imposed limit, without any further action after satellite end of life. This maximal altitude is for most typical satellite's Area-to-Mass Ratio (AMR) lying between 550 – 650 km,
- Implement and use “passive” de-orbiting devices like drag/solar sail (DRS/SRS) or tethers, and use (or not) active attitude control to increase the decay rate by optimizing the satellite attitude with respect to deorbit needs,
- Use remainings of on-board propellant to reach, during disposal an orbit altitude ensuring natural decay within the imposed limit, without any further action after spacecraft end of life. This method using the satellite propulsion subsystem is called “Indirect re-entry” in [OHB],
- Use dedicated on-board propulsion resources to perform a controlled, direct re-entry from the satellite end of operation orbit to an orbit altitude of about 120 km. This second method using the satellite propulsion subsystem is called “Direct re-entry” in [OHB].

Each of these methods has advantages and drawbacks (inc. obligation for passivation) that needs to be considered early in the project development cycle to identify the most suitable to use for the specific project.

1.2. The Dragsail GNC (DGNC) Project

DGNC stands for Dragsail Guidance, Navigation & Control (GNC). It is a LuxSpace project developed within the ESA CleanSpace initiative and is aiming at identifying the best GNC solution to be proposed for satellite (debris) deorbiting when using Dragsails.

In line with the possible methods listed in the previous section, the proposed and investigated GNC options are:

- (1) no attitude control during deorbit,
- (2a) active attitude control constantly maximizing the area exposed to drag, this with a flat Dragsail, and,
- (2b) active attitude control constantly maximizing the area exposed to drag, this with a pyramidal (arrow) Dragsail.

The first part (now completed) of the DGNC project was mainly devoted to data collection and trade-off analyses targeting the identification of the optimal DRS/SRS configuration (defined by number of booms, size and shape) for a given reference mission. For each DRS/SRS configuration, the performed trade-offs compared Sat+DRS/SRS parameters relating to:

- Physical aspects like dimensions, mass and inertias,
- DRS/SRS complexity/dependability aspects,
- Deorbit durations,
- GNC aspects like stability and average/maximal environmental perturbations impacting the attitude during deorbit.

Data collection involved the NASA DAS tool and also several specific LuxSpace-developed spreadsheet tools, as well as the GNC (S-) MIL i.e. a dedicated simulation tool created and validated within the ESA-supported GNCDE development environment.

Comparisons with the other methods using (if available) the satellite propulsion subsystem were also established during the first part of the project.

The second part (now initiated) of the DGNC project will concentrate on the ADCS/GNC subsystem design and sizing for the active attitude control of this optimal Sat+DRS/SRS configuration. FDIR and operational implications will also be investigated to consolidate the project conclusions about best GNC solution for drag-augmented deorbiting phases.

1.3. Outline of the Paper

After this introductory chapter (1), the paper proceeds with:

- (2) the description of the DGNC (by now only: S-) MILs developed within GNCDE,
- (3) the validation of the DGNC S-MIL with real de-orbited missions and with the NASA DAS tool,
- (4) the presentation of the project's results achieved so far,
- (5) the anticipation of the last project's activities to be performed for the Final Presentation scheduled before Summer 2016.

2. DGNC MIL TOOL(S) WITH GNCDE

2.1. DGNC and GNCDE

The scope of the DGNC project is to design and prototype the optimal ADCS/GNC subsystem to de-orbit a spacecraft in LEO orbit by means of deployable sails that use drag augmentation to accelerate its orbit decay.

In order to perform such design it was necessary to develop a simulation tool able to estimate the deorbiting time of a satellite equipped with a drag/solar sail (DRS/SRS) taking into account the spacecraft real attitude and any aspect related to attitude control.

The necessary MIL simulation tool(s) is/are thus required to assess controllability and effectiveness of sails in various ADCS/GNC configuration and modes.

The tool(s) shall also be used to support spacecraft system analysis and design with trade-offs regarding the sail configuration. The output of the simulations shall support the design of an ADCS/GNC subsystem for orbit and attitude control using the drag augmentation device.

Furthermore the tool(s) shall include an ADCS/GNC functional model that includes the Failure Detection, Isolation and Recovery (FDIR) as well as drag augmentation device activation logic.

In terms of models/ functionalities the MIL simulation tool(s) is/are thus required to provide the following:

- Satellite dynamics,
- Environmental models (for external disturbances),
- Sensitivity and robustness analyses,
- Stability and controllability aspects,
- Equipment (sensors and actuators) models,
- Attitude estimation and control algorithms,
- CAD/geometry interface,
- GUI,
- Functional model (including FDIR).

Before starting the DGNC project, a "Make or Buy" decision was made between the full internal development of the code or the purchase of an external software for the implementation of several project-specific functionalities.

The choice for the external software GNCDE, developed by GMV under ESA contract, as support tool was the outcome of such analysis, mainly for the reason that it is already a complete and validated tool, with a User interface and additional toolboxes dedicated to Monte Carlo and Sensitivity analyses. All the conventional models of a spacecraft are included together with the environmental ones [GNCDE].

What was then required from LuxSpace was to create the new model/functionalities relative to the DRS/SRS-specific geometry and to the controllability of such large, flexible structures, and to implement them in the existing GNCDE templates/GUI.

2.2. Capabilities of the S-MIL Tool

The first version of the tool, named S(imple)-MIL, is able to propagate the attitude and orbital motion of a satellite (+DRS/SRS) in LEO taking into consideration its actual attitude at each time step.

In particular the tool derives the deorbiting time starting from the initial condition down to an altitude of 200 km, where the deorbit phase is considered completed.

The output of this simulation consists in a sub-set of parameters (simulation time, system reliability, orbital parameters, attitude Euler angles, angular speeds, external accelerations and torques and stability index) which can be used for a preliminary design of the sail and the ADCS/GNC subsystem.

The tool offers the possibility to define the satellite (+DRS/SRS) geometry and to evaluate the external disturbances based on the actual attitude at each time step. Furthermore it is possible to set up the initial conditions (including the beta angle) and which disturbances to be taken into account.

An average simulation using an Intel CPU with 2 processors running at 2.4 GHz and 12 cores takes about 1.7 ± 1.5 (1σ) hours per simulated year. The main issue related to computation time is that the actual version of the S-MIL under GNCDE is running only on one core.

2.3. Design of the S-MIL Tool

This S-MIL simulation tool provides the following models/functionalities:

- Satellite dynamics:
 - Kinematics,
 - orbital motion.
- Environmental models (external disturbances):
 - geo-potential,
 - aerodynamics,
 - radiation pressure (including eclipses),
 - geo-magnetic field,
 - third body (Luni-Solar) perturbation.
- Sensitivity and robustness analyses:
 - initial orbit (including starting date),
 - sail shape (Area).
- Stability and controllability aspects,
- Sat+DRS/SRS geometry interface,
- GUI.

The approach used for computing the geometry based disturbances like solar radiation pressure and aerodynamic acceleration consists in dividing the satellite geometry in elementary areas. For each of them the elemental force is computed and the moment retrieved with a cross product with the vector from the center of mass of the satellite to the application force point.

The application points (center of solar and aerodynamic pressure) are considered coincident with the geometric center of each elemental area.

Once all the elemental forces and torques are computed, the resulting disturbances are obtained by adding the single contributions.

An analytical condition for the stability index computation is also included in the S-MIL. This formulation makes a simplified balance between the gravity gradient and aerodynamic torques acting on a satellite in LEO. By analyzing the pitch and yaw dynamics a reduced condition for stability can be expressed [STAB].

However this index can be used only to have an idea of the possibility to stabilize a spacecraft passively. Further investigation of this index shall be performed using simulation data, which includes also other disturbances and non-linear effects.

In particular aerodynamic shadowing could have a major impact on this index. Such shadowing is not part of the S-MIL but will be included in the C-MIL.

The tool can work in two different attitude modes: in Fixed or in Tumbling mode.

In the **Fixed mode** the attitude is kept constant: the attitude quaternion is computed from the instantaneous position and velocity vector and no attitude propagation is made. The satellite in this mode is always pointed with its x-axis towards the velocity vector. This pointing vector can be also off-pointed from this condition by defining in the initial parameters the desired tilting angle.

In the **Tumbling mode** the attitude propagation is the result of the total torque acting on the satellite and therefore the satellite motion is tumbling. This mode is of particular interest in order to evaluate uncontrolled system and to evaluate the pointing (passive) stability for the considered configuration.

The S-MIL simulation tool block diagram and the steps needed to run a simulation are presented in Figure 1.

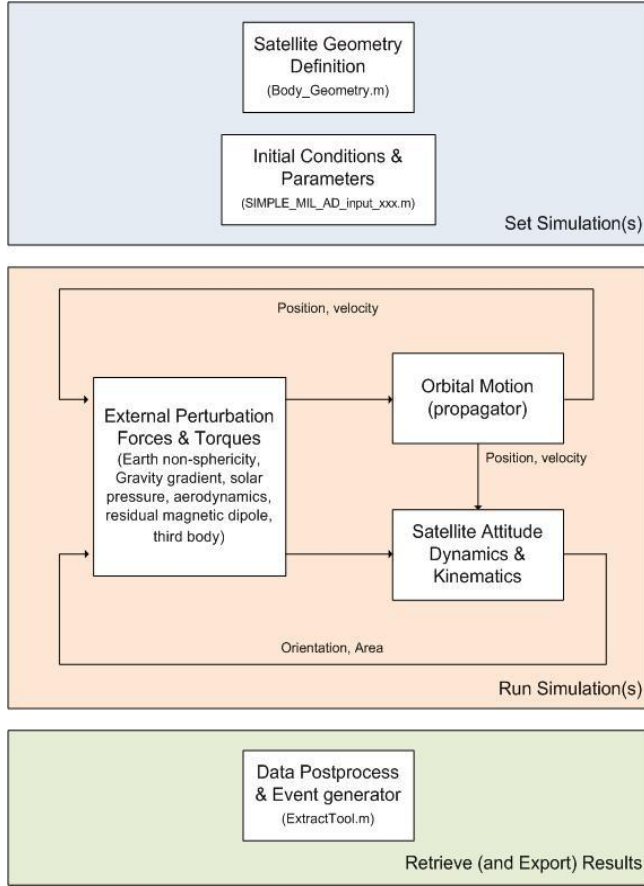

Figure 1: S-MIL block diagram

2.3.1. Set simulations

The first step to be done in order to run a S-MIL simulation is to initialize the geometry. This process is supported by an additional Matlab® file where the User can generate the geometry of the satellite by inserting the coordinates of its vertexes and the relative optical properties. The script computes in automatic the area, the normal vector and the center of mass of each satellite surface (considered coincident with the geometric center).

In order to ease the check of the correct implementation, the script outputs also the figure of the satellite (+DRS/SRS) as defined (see Figure 2) together with the vectors normal to each face. The outcome of this script is a matrix containing one row per satellite face. This matrix has to be copied and pasted in the initialization file of the S-MIL. The elements included in each row will be used in the computation of the elementary aerodynamic and solar radiation pressure forces and torques.

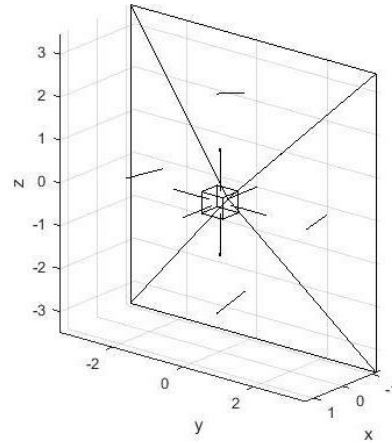

Figure 2: Example of output geometry

The second step to perform is to compile the initialization file of the simulation. Other than the geometry matrix previously mentioned, the following parameters shall be defined:

- Simulation step size [s],
- Flag for Drag and Solar surface computation [0=constant, 1=geometry based],
- Value of the constant exposed Drag area, drag coefficient, position of the center of pressure,
- Physical constants structure (Earth Dipole Longitude, Earth Dipole Co-elevation and Earth Dipole modulus),
- Magnetic Residual Dipole Magnitude and direction,
- Number of zonal and tesseral terms,
- Solar radiation pressure constant [W/m²],
- Value of the constant exposed Solar area with its specular and diffuse reflection coefficients,
- Satellite mass and inertia,
- Disturbances flags (1=enable),
- Attitude selection (0=no control, 1=constant orientation),
- Initial Simulation Date [YYYY.dddd],
- Initial Orbital Parameters [km and deg] [perigee altitude, apogee altitude, inclination, RAAN, argument of periapsis and true anomaly],
- Initial tilting angles of the satellite, order roll, pitch, yaw [deg],
- Initial angular velocities of the satellite [deg/s],
- Lambda (for the reliability computation).

All these parameters have a default value generated automatically in the initialization file.

2.3.2. Run simulations

In order to run the simulations it is necessary to use the GNCDE GUI:

In the main window the <GNCDE Manager> command shall be selected and in the following window (<Template Manager>) the S-MIL template shall be selected together with the required initialization file.

Once all the parameters are checked, the <Run Manager> window shall be selected and the simulation runs.

2.3.3. Retrieve and export results

Once the simulation is completed, the S-MIL generates an output file containing for each processing step:

- Simulation Time in seconds,
- Simulation Date in MJD format,
- Reliability,
- Six orbital parameters locating the satellite,
- Euler angles defining the satellite attitude with respect to ECI reference frame,
- Angular velocities of the satellite,
- Aerodynamic, solar radiation pressure and total external forces,
- External torques acting on the satellite (single torques and total torque),
- Estimated Cross Area (with respect to velocity vector),
- Stability associated index (1=yes/0=no).

The sampling of the output file can be set by the User in order to reduce the size of the file itself.

The information contained in this output file allows analyzing the full behavior of the satellite during deorbiting without re-running the simulation. Moreover this file can be imported in the GNCDE software to perform sensitivity and Monte Carlo analyses.

Examples of output plots can be seen in the following pictures [DGNC-2].

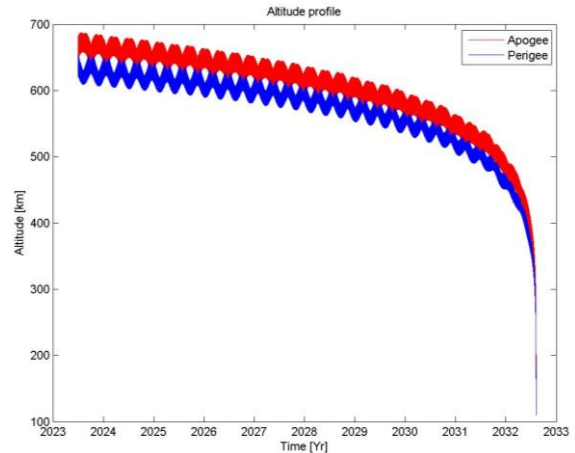

Figure 3: Example of output altitude profile

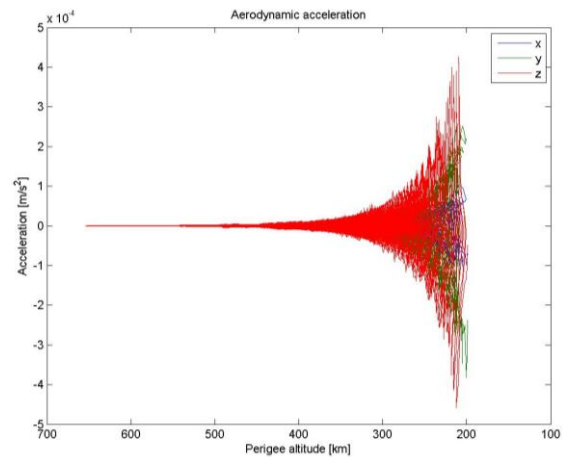

Figure 4: Example of aerodynamic acceleration profile

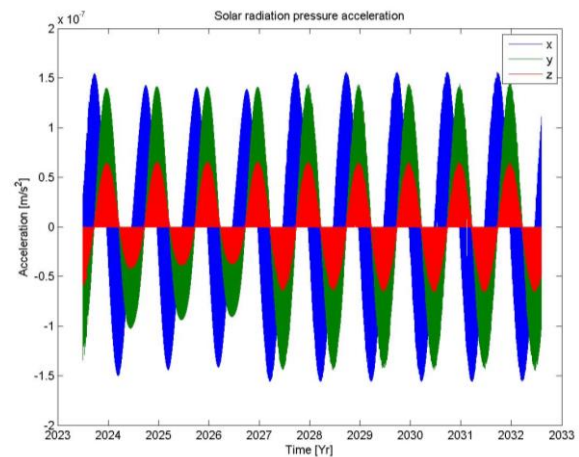

Figure 5: Example of solar radiation pressure acceleration profile

This output file is to be post-processed by an additional Matlab® file which identifies a set of meaningful events and for each of them reports the corresponding output.

This post-processing sorts (according to their date) the following events:

- Start (T0) and Stop (Tend) of Deorbit (and relative total duration),
- (T) Time when perigee altitude crosses for the first time the next lower altitude (defined by multiples of 50 or 100 km),
- (R) Time where the Reliability is closest to a 1 decimal fixed value (e.g. 0.9, 0.8, 0.7 ...),
- (S) Time where the stability index changes (e.g. satellite becomes stable/unstable),
- (SA) The mean stability index,
- (DI) Time where the satellite rotational acceleration is maximum,
- (DE) Time where the external disturbance torques are maximum,
- (DEX, DEY, DEZ) The mean external disturbance torques,
- (DC) Time where the module of the aerodynamic and solar radiation pressure forces are comparable.

Practically, it is proposed to use the S-MIL to identify these events and further investigate a sub-set of them using a more detailed/complex version of the simulation tool (i.e. the C-MIL) for few orbits.

2.4. Capabilities of the (future) C-MIL Tool

The C(omplex)-MIL represents an upgrade of the S-MIL and it has the objective to compute the real Area-to-Mass Ratio (AMR) during deorbiting and better estimate the respective deorbiting time.

The C-MIL will therefore implement all the non-linear models related to DRS/SRS flexibility, sensors and actuators (conventional and non-conventional) together with their degradation and reliability.

Non-conventional actuators consist in Gimbaled Control Boom, Control Vanes and Sail Panel rotation. All these actuators were modelled and analyzed in literature for solar sails control for interplanetary mission [ACT].

Estimation and control algorithms will be implemented so the spacecraft orientation will be function of the satellite dynamics/kinematics and the control law selected (with its relative performance error).

The C-MIL shall be seen as complement to the S-MIL. Due to its complexity and consequent computation time, this tool shall not be used for a full run (i.e. up to 25 years) simulation.

The C-MIL shall therefore analyze few identified orbits, where the behavior of the system needs further investigation. As example it could simulate the orbit when the actuators reliability is less than a given threshold or when the aerodynamic torque is equivalent to the torque induced by solar radiation pressure disturbance.

3. S-MIL VALIDATION WITH NASA DAS

Although most of the single mathematical models were developed and validated during the design of the GNCDE software, it was necessary to evaluate if the S-MIL results are in line with the expectations. Therefore a comparison was required with existing deorbit software and with real deorbit data.

3.1. Validation Test Cases

The first step in the validation process was to identify a set of satellites whose deorbit time is known. Preference in the selection was given to satellite with simple shapes (sphere, cubes) which deorbited in a limited amount of time (i.e. few years).

The set of validation test cases consists of 7 satellites:

- **SFERA**: spherical S/C, starting perigee altitude: 402 km, AMR = 0.0170 m²/kg, real deorbit time 0.2630 yrs,
- **Ande-Castor**: spherical S/C, starting perigee altitude: 328 km, AMR = 0.0037 m²/kg, real deorbit time 1.0711 yrs,
- **INVADER**: 1U cubesat, starting perigee altitude: 380 km, AMR = 0.0091 m²/kg, real deorbit time 0.5105 yrs,
- **Dove-1**: 3U cubesat, starting perigee altitude: 236 km, AMR = 0.0071 m²/kg, real deorbit time 6 days (0.0146 yrs),
- **Navid**: 50 cm cubic S/C, starting perigee altitude: 276 km, AMR = 0.0091 m²/kg, real deorbit time 0.1584 yrs,
- **GEO-IK2**: prismatic S/C with 2 solar wings, starting altitude: 356x993 km, AMR = 0.0151 m²/kg, real deorbit time 2.4495 yrs,
- **NanoSail-D2**: 3U cubesat equipped with a 10m² square sail, starting altitude 640 km, AMR = 1.07 m²/kg, real deorbit time 0.6571 yrs.

The real deorbit time was extracted mainly from archived TLEs and was estimated using the NASA DAS tool. This tool is able to generate also the altitude profile for each of the considered cases.

Obviously these DAS predictions rely on the accuracy of the data provided as input. In particular it was difficult to set the exact AMR mainly because the (averaged) exposed spacecraft area during deorbit depends on the spacecraft attitude all along the deorbit trajectory, which is unknown.

3.2. Comparison of Results

Two different comparisons were made: a quantitative and a qualitative. The first consists in comparing the real deorbit time with those given as output from S-MIL and DAS, while the second compares the (perigee and apogee) altitude profile generated by the two software.

3.2.1. Quantitative comparison

The results from the S-MIL were compared with real deorbit data and with the outcome of NASA DAS.

The real deorbiting time was retrieved from archived TLEs and from publicly available durations, while the DAS deorbiting was computed considering the minimum and the maximum AMRs for the considered satellite. In Table 1 the outcome of the simulation cases are presented in terms of deorbiting time computed by the S-MIL and the ratio between this value and the one from real and DAS data. The satellite for this analysis is considered deorbited at 150 km altitude.

Satellite	S-MIL (yrs)	S-MIL/Real	DAS/Real
SFERA	0.2766	1.05	1.58
Ande-Castor	0.2314	0.22	0.88
INVADER	0.3642	0.71	1.01
Dove-1	0.0176	1.20	1.85
Navid	0.1111	0.70	0.90
GEO-IK2	2.9621	1.21	1.38
NanoSail-D2	0.4006	0.61	1.00

Table 1: Quantitative comparison of S-MIL results

On this validation set, the NASA DAS tool provides on average a deorbiting time equal to 1.19 times the real one, with minimum and maximum factors being respectively 0.88 and 1.85.

On this validation set, the S-MIL tool provides on average a deorbiting time equal to 0.85 times the real one, with minimum and maximum factors being respectively 0.22 and 1.21. Excluding the single case (i.e. Ande-Castor) leading to this minimal factor (0.22) from the validation set, the S-MIL tool provides in average* a deorbiting time equal to 0.86 times the real one, with minimum* and maximum factors being now respectively 0.61 and 1.21.

Thanks to these comparisons, it was concluded that the S-MIL generates deorbit durations similar to the real ones (as the NASA DAS does) and that by this, it could be considered as validated quantitatively.

3.2.2. Qualitative comparison (wrt DAS)

Qualitative comparisons were performed by overlaying the altitude profiles calculated by S-MIL and by DAS.

For this, it was ensured that perigee altitude scales were kept coincident between the two curves and that only the temporal scale would be stretched as needed to ensure coincidence of the first and last reference perigee altitudes. An example of this qualitative comparison is shown on Figure 7, while Figure 6 here below shows a quantitative check also performed graphically.

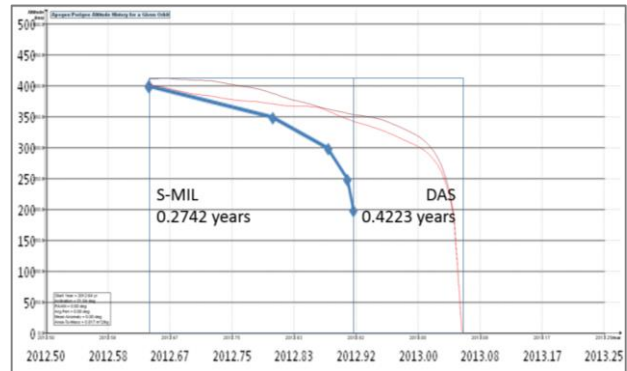

Figure 6: Example of quantitative check (SFERA)

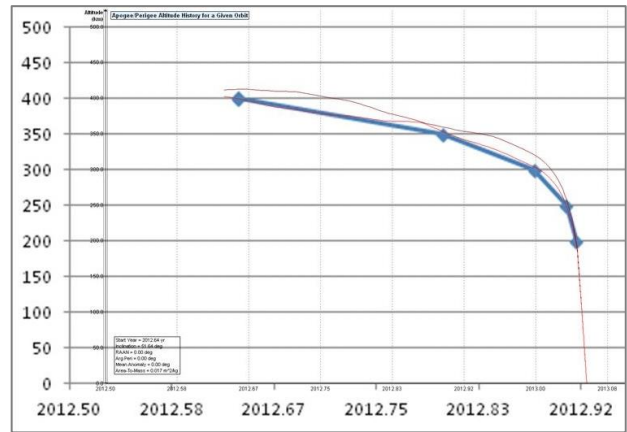

Figure 7: Example of qualitative comparison (SFERA)

On this validation set, the S-MIL and DAS generated similar perigee and apogee profiles.

Thanks to these comparisons, it was concluded that the S-MIL could also be considered as validated qualitatively and by this, that it could be used for the purpose of the DGNC project.

4. MAIN RESULTS OF DGNC

4.1. System Trade-offs

As anticipated at the beginning of the paper, the first part (now completed) of the DGNC project was mainly devoted to data collection and trade-off analyses targeting the identification of the optimal DRS/SRS configuration (defined by number of booms, size and shape) for a given reference mission [DGNC-1].

Four DRS/SRS configurations have been defined and investigated:

- **Arrow:** a DRS/SRS made of 4 sail segments featuring a pyramidal shape and directly attached to the spacecraft/debris,
- **Flat:** a special Arrow configuration where the pyramidal angle is equal to 0 deg,
- **Arrow Offset:** a DRS/SRS made of 4 sail segments featuring a pyramidal shape and offset (with an additional boom of same size as the one used for the sail segments) with respect to the spacecraft/debris,
- **Flat Offset:** a special Arrow Offset configuration where the pyramidal angle is equal to 0 deg.

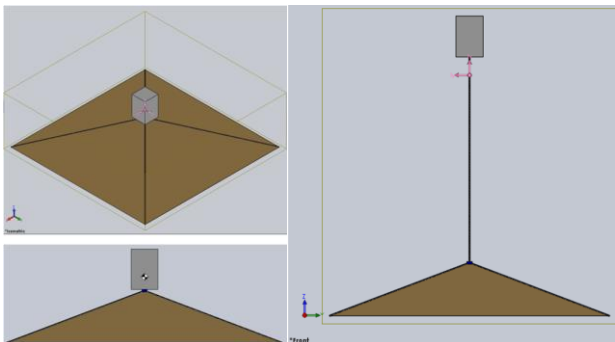

Figure 8: Arrow and Arrow Offset DRS/SRS

In the various analyses/simulations for the system trade-off, the DRS/SRS had to support a 1000 kg, 3m x 2m x 2m satellite starting its deorbit from a 650 km orbit after mid-2021.

For each DRS/SRS configuration, the performed trade-offs compared Sat+DRS/SRS parameters relating to:

- Physical aspects like dimensions, mass and inertias:
 - Booms lengths were selected from the set: [3.54 ; 5.0 ; 10.0 ; 15.0] m,
 - Pyramidal angles were selected from the set: [0 ; 5 ; 10 ; 15 ; 30 ; 45] deg.

- DRS/SRS complexity/dependability aspects, here mainly differentiating the Offset configurations requiring (the deployment of) an additional boom,
- Deorbit durations, as calculated by DAS and by the S-MIL,
- GNC aspects like stability and average/maximal environmental perturbations impacting the attitude during deorbit, as calculated by the S-MIL.

For the trade-offs, three set of weights for each evaluation measure/parameter were defined:

- **Balanced:** with this set, an attempt was made to balance the three main parts of the trade-off:
 - DRS/SRS physical and dependability aspects, totaling 30% of the weights
 - Deorbit durations, totaling 25% of the weights
 - GNC aspects, totaling 45% of the weights
- **GNC Torque Components:** with this set, preference was given to the GNC aspects, expressed as the three components of the absolute average of the external torque acting of the Sat+DRS/SRS during deorbit:
 - DRS/SRS physical and dependability aspects, totaling 20% of the weights
 - Deorbit durations, totaling 20% of the weights
 - GNC aspects totaling, 60% of the weights (of which 0% for torque modulus)
- **GNC Torque Modulus:** with this set, preference was given to the GNC aspects, expressed as the modulus of the absolute average external torque acting of the Sat+DRS/SRS during deorbit:
 - DRS/SRS physical and dependability aspects, totaling 20% of the weights
 - Deorbit durations, totaling 20% of the weights
 - GNC aspects totaling, 60% of the weights (of which 40% for torque modulus)

Without entering here into the details, the system trade-offs allowed to derive the following conclusions for the analysed mission (i.e. 1000 kg object starting its deorbiting from 650 km altitude in 2023.5):

- **“Avoid Offset DRS/SRS Configurations”:** these configurations indeed did not brought the expected increased stability and instead, are more heavy and complex to deploy.
- **“Better Flat than Arrow shaped”:** except for tumbling cases with small booms AND only in the trade-offs focusing on GNC aspects, the arrow configurations did not brought the expected benefits.
- **“Optimise Boom Length”:** the best is half-way between the extremes as masses, complexity and

torques privilege small DRS/SRSs, while (short) deorbit durations privilege large DRS/SRSs.

4.2. Results for the Nominal Case

As a design exercise, a Nominal Case has been defined.

Basically this Sat+DRS/SRS configuration is very close to one of the test cases simulated for the trade-offs and it differs only by the fact that the satellite dimensions are not 3 x 2 x 2 m but 3 x 2 x 1.8 m. The Nominal DRS/SRS configuration is Arrow 10 deg built with booms of 3.54m. The resulting Nominal Sat+DRS/SRS is depicted here below:

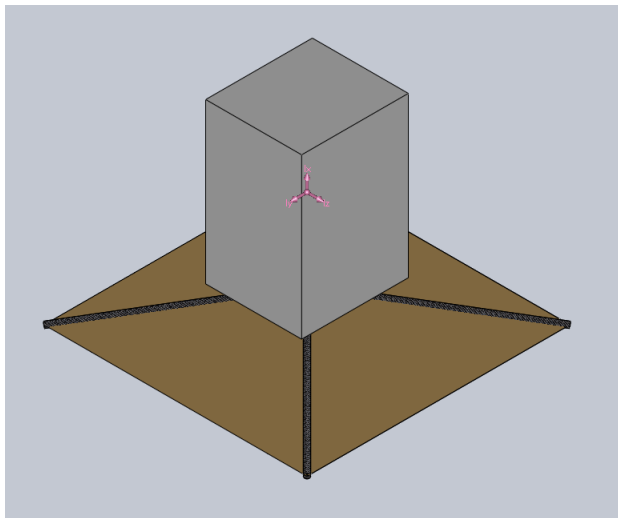

Figure 9: DGNC Nominal Case

Such a satellite (debris) will require some deorbiting means as it would necessitate (without any DRS/SRS) nearly 50 years to deorbit from a 650 km orbit.

According to the simulations performed with the S-MIL, the Nominal Sat+DRS/SRS will re-enter in 11.5 years if continuously, actively controlled or, in 14.8 years if left tumbling. Experienced external torques are larger in the tumbling mode.

On the other side, if any propulsion subsystem is (still) available:

- **Indirect re-entry:**
 - with chemical propulsion (Isp 300 sec), will need few hours and only 5.0 kg of propellant (remainings) to reach the target (650x595 km) orbit to start from there its 25 years deorbit/re-entry,
 - with electrical propulsion (Isp 3000 sec), will need few days and only 0.3 kg of propellant (remainings) to reach the target (620 km) orbit to start from there its 25 years deorbit/re-entry.

- **Direct re-entry** (to 200 km orbit):
 - with chemical propulsion (Isp 300 sec), will need few days and 82.5 kg of propellant to reach the 200 km orbit to start from there its re-entry,
 - with electrical propulsion (Isp 3000 sec), will need about one year and 10.3 kg of propellant to reach the 200 km orbit to start from there its re-entry.

5. NEXT ACTIVITIES TO END OF PROJECT

The DGNC project will bring its full conclusions before Summer 2016.

Still to be done are the tasks relating to:

- Design and modelisation of the ADCS/GNC subsystem (and its FDIR) architecture required for the active attitude control of Sat+DRS/SRS during deorbit,
- Upgrade of the S-MIL into the C-MIL and verification of the proposed ADCS/GNC architecture with this C-MIL tool,
- Compilation of the project synthesis and the final recommendations with respect to best GNC solution for satellite (debris) deorbiting thanks to Dragsails.

6. REFERENCES

[ACT] B. Wie, “Dynamic Modeling and Attitude Control of Solar Sail Spacecraft”, NASA Solar Sail Technology Working Group (SSTWG), JPL Contract No. 1228156, Final Report, January 10, 2002

[DGNC-1] LuxSpace document DGNC-LXS-RP-0003 (Issue 1/A, dated 26/02/2016) “System Analysis & Design”

[DGNC-2] LuxSpace document DGNC-LXS-RP-0004 (Issue 1/A, dated 26/02/2016) “MIL Simulations”

[ECSS-U-AS-10C] ECSS Standard “Adoption Notice of ISO 24113: Space Systems – Space debris mitigation requirements”

[GNCDE] GMV, “GNCDE3 Software User’s Manual”, Madrid, 2015.

[OHB] Final Report “End-Of-Life De-Orbit Strategies”, Doc. ref. EOL-OHB-FR-001 (Issue: 1 ; Date: 03.07.2002)

[STAB] T. Bak and R. Wisniewski, “Passive Aerodynamic Stabilization of a Low Earth Orbit Satellite”, Spacecraft Guidance, Navigation and Control Systems, Proceedings of the 3rd ESA International Conference, Noordwijk, 26-29 November 1996