

Impact of the consideration of AE9/AP9 models on the space radiation environment specification

*J. Guillermin and A. Varotsou, TRAD
D. Standarovski and R. Ecoffet, CNES*

- The AE9/AP9 radiation belt models are currently being developed with the goal to replace the legacy AE8/AP8 models in the future.
- These models can be run with different configurations – choices to be made by engineers
- Important differences in particle flux predictions have been observed between Ax9 and Ax8 models as well as orbit-specific European standards [Huston et al., 2013, Bourdarie et al., 2014 & 2016].

- How will the radiation environment specification be impacted by the new models?
- What is the impact on component level radiation analysis?
- What is the impact of the chosen configuration on the result?

- Description of activities
- Results for TID/TNID
- Results for transported fluxes
- Conclusions
- Final remarks

- AE9/AP9 v.1.30.001 (January 2016) was used
- Determine the impact on:
 - Particle fluxes
 - Dose-depth curve
 - Equivalent fluence-depth curve (10 MeV protons)
 - Calculations with a realistic 3D radiation model
 - Monte Carlo calculations
 - Ray-tracing calculations
 - Transported fluxes (10 MeV & 60 MeV protons)
- Estimate the difference with results obtained with current standard models

- Definition of the radiation environment with AE9/AP9 for different space missions
 - ▶ Here we present:
 - LEO: 1336 km, 66°, 7 years
 - GEO: 35 784 km, 0°, 15 years (160°W)
 - Electrical Orbital Rising transfer
 - from a GTO orbit with a perigee of 200 km (200 km x 35486 km, inclination = 7 deg)
 - ▶ Comparison with models commonly considered
 - AE8/AP8
 - IGE2006 for GEO

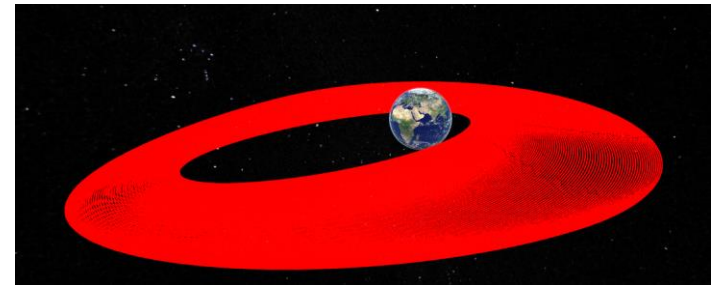

- Different configurations of Ax9 were studied:
 - ▶ Mean
 - ▶ Perturbed mean (40 scenarios): mean, median, 90% percentile
 - ▶ Monte Carlo (40 scenarios) : mean, median, 90% percentile

- For TID/TNID:
 - ▶ Mean and Perturbed mean

- For SEE (transported fluxes):
 - ▶ Mean and Monte Carlo

- Description of the 3D radiation model
 - ▶ ICARE equipment model
 - ▶ JASON2 satellite model
 - ▶ Selection of devices at different locations

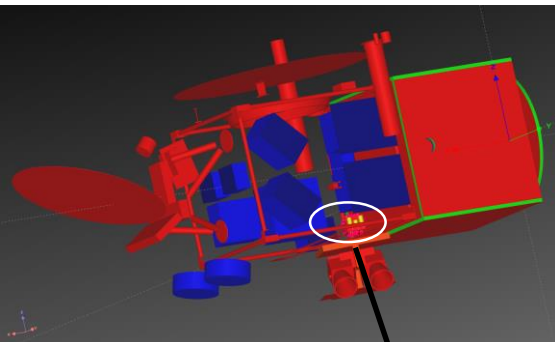

Detector	Device
6	OPA683
52	AD8011
86	LT1415
185	STPS3L60
272	K4S560432
284	IRFC360

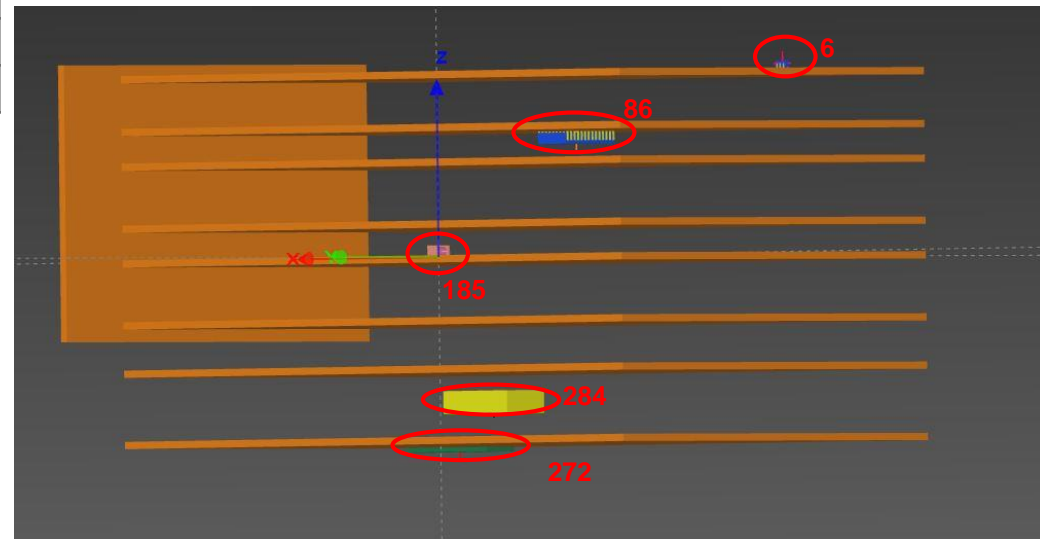
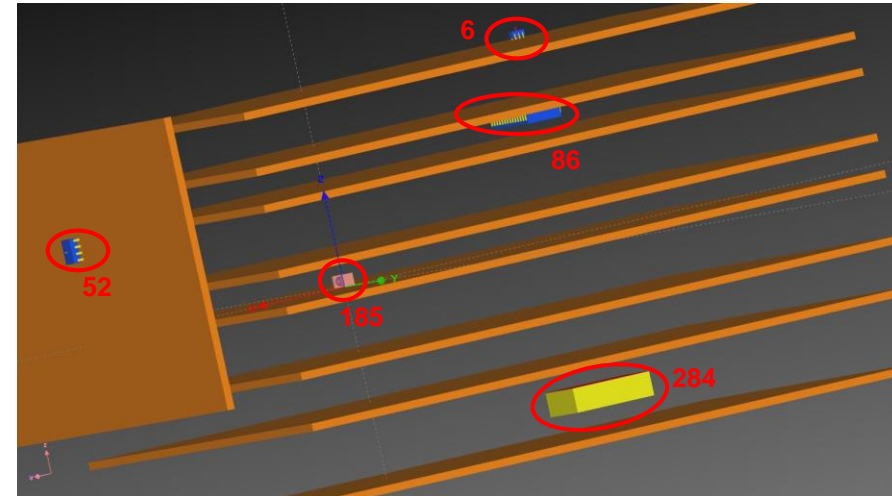
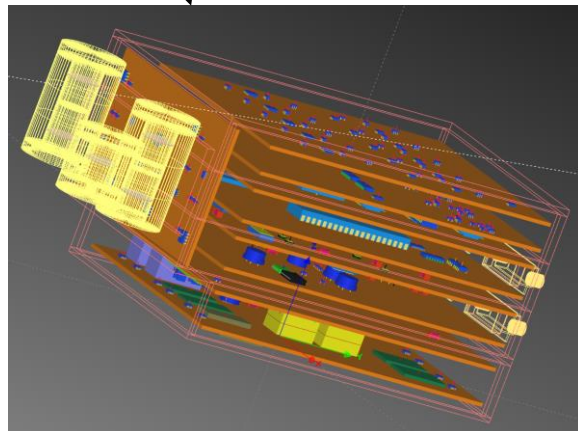

- Trapped protons for LEO (1336 km, 66°, 7y)

◆ AP8 min
 ▲ AP9 Mean
 □ AP9 Perturbed Mean - Percentile 90%
 ● AP9 Perturbed Mean - Mean
 ◇ AP9 Perturbed Mean - Median

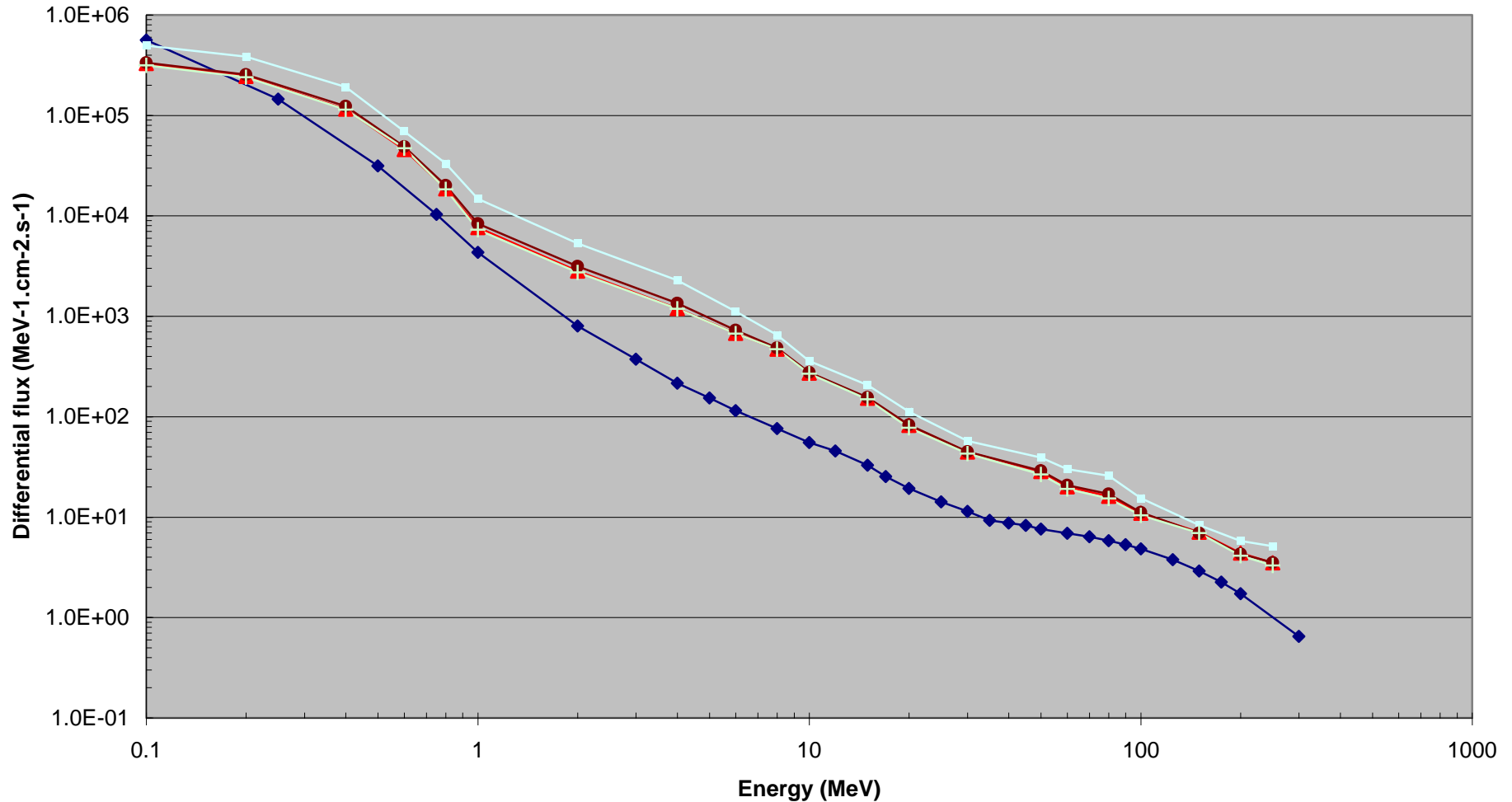

- Trapped electrons for LEO (1336 km, 66°, 7y)

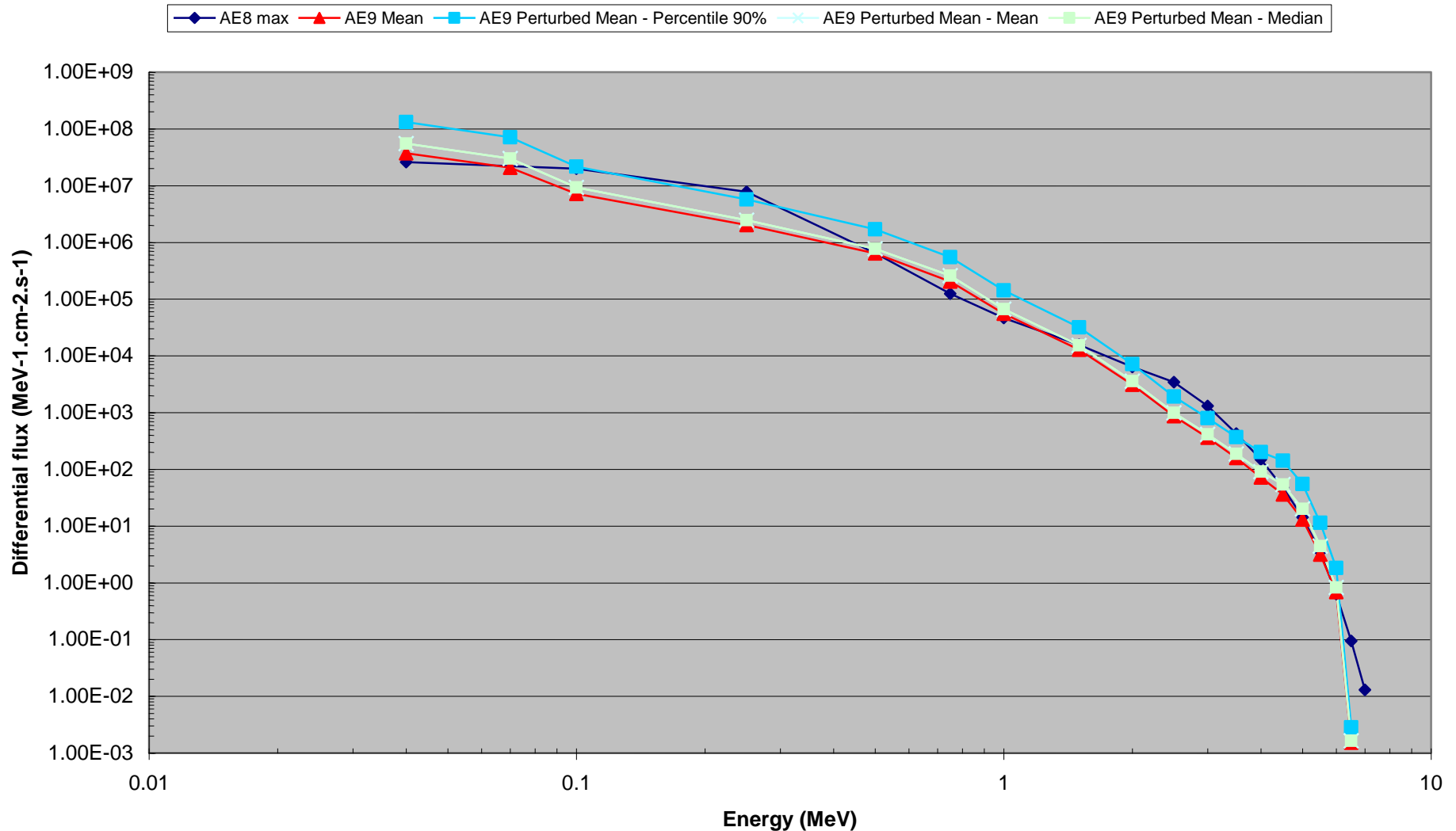

- Dose-depth curve for LEO (1336 km, 66°, 7y)

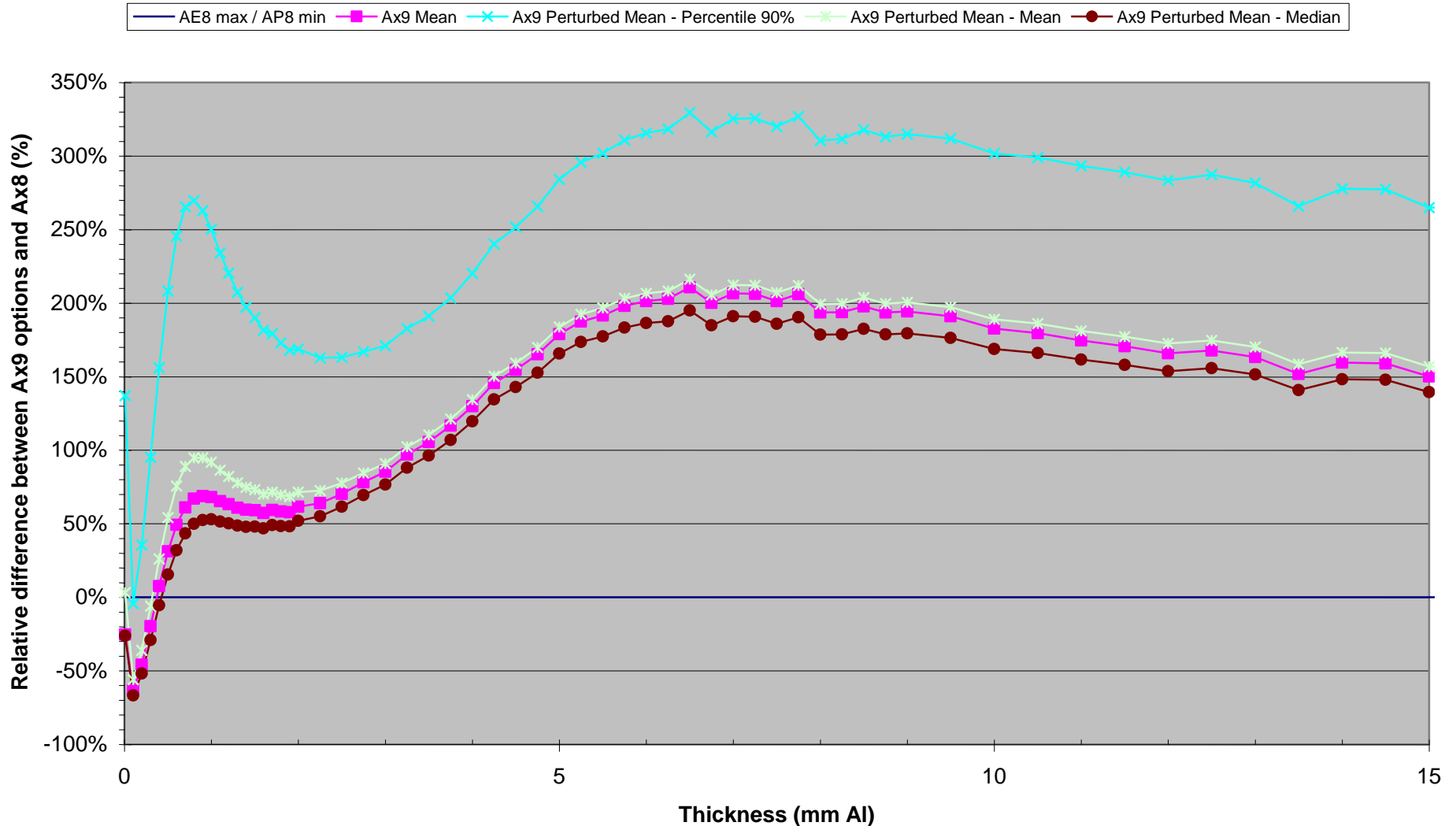

- Equivalent fluence-depth curve for LEO (1336 km, 66°, 7y)

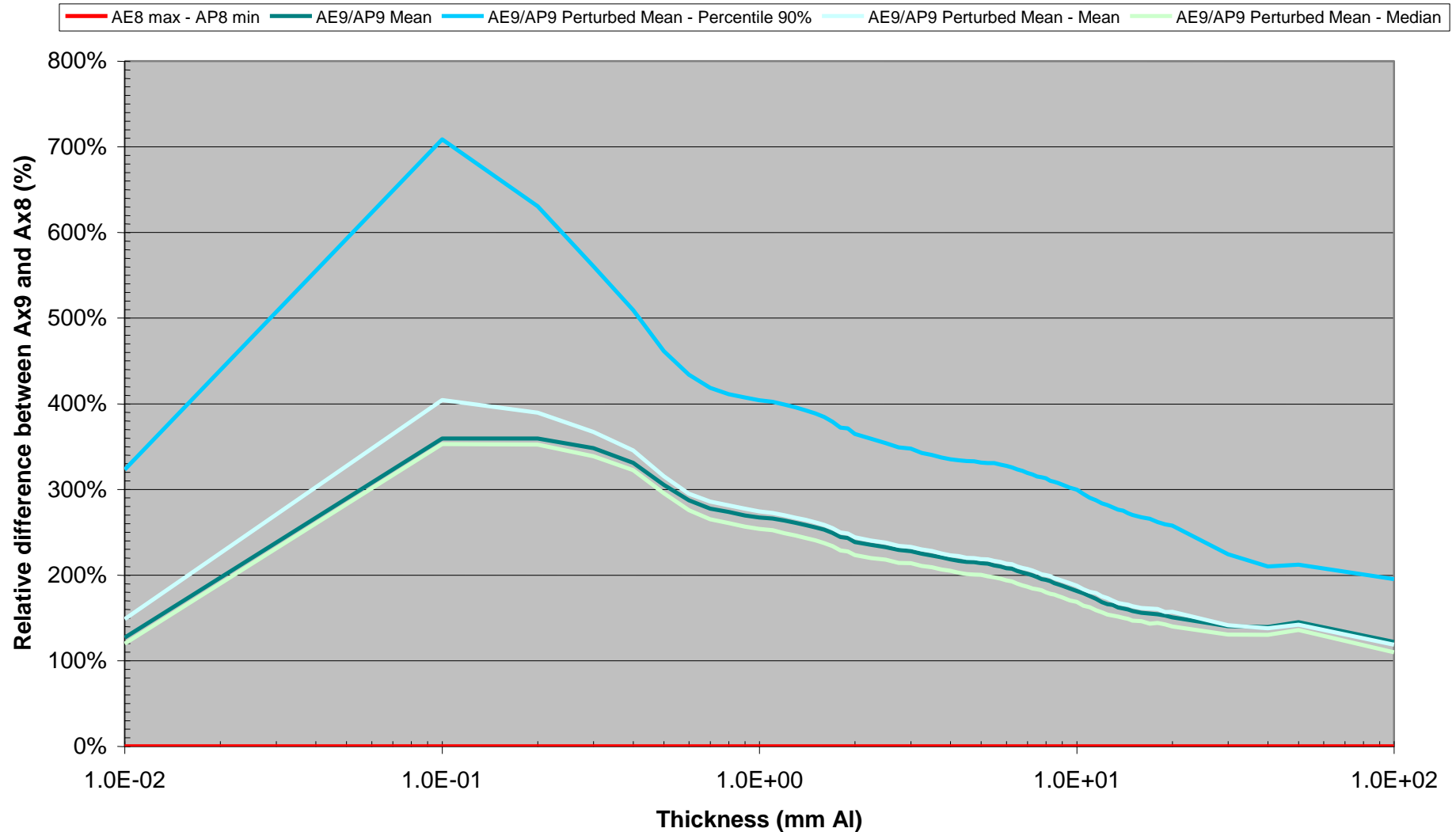

- Monte Carlo results for LEO (1336 km, 66°, 7y)

Detector	Device	Total Ionizing Dose by Monte Carlo			
		Relative difference Ax9/Ax8 (%)			
		AE9 AP9 mean	AE9 AP9 PM mean	AE9 AP9 PM median	AE9 AP9 PM Perc. 90%
6	OPA683 - Z18	150	154	139	250
52	AD8011 - Z50	142	145	132	236
86	LT1415 - Z7	140	143	130	235
185	STPS3L60 - D16	140	143	130	234
272	K4S560432 - Z58	161	165	149	262
284	IRFC360 - T12	140	142	130	231

Detector	Device	Total Non Ionizing Dose by Monte Carlo			
		Relative difference Ax9/Ax8 (%)			
		AE9 AP9 mean	AE9 AP9 PM mean	AE9 AP9 PM median	AE9 AP9 PM Perc. 90%
6	OPA683 - Z18	148	151	137	243
52	AD8011 - Z50	141	143	131	229
86	LT1415 - Z7	139	141	129	228
185	STPS3L60 - D16	138	140	128	227
272	K4S560432 - Z58	164	168	153	264
284	IRFC360 - T12	138	140	128	225

- Trapped electrons for GEO (35 784 km, 0°, 160°W, 15y)

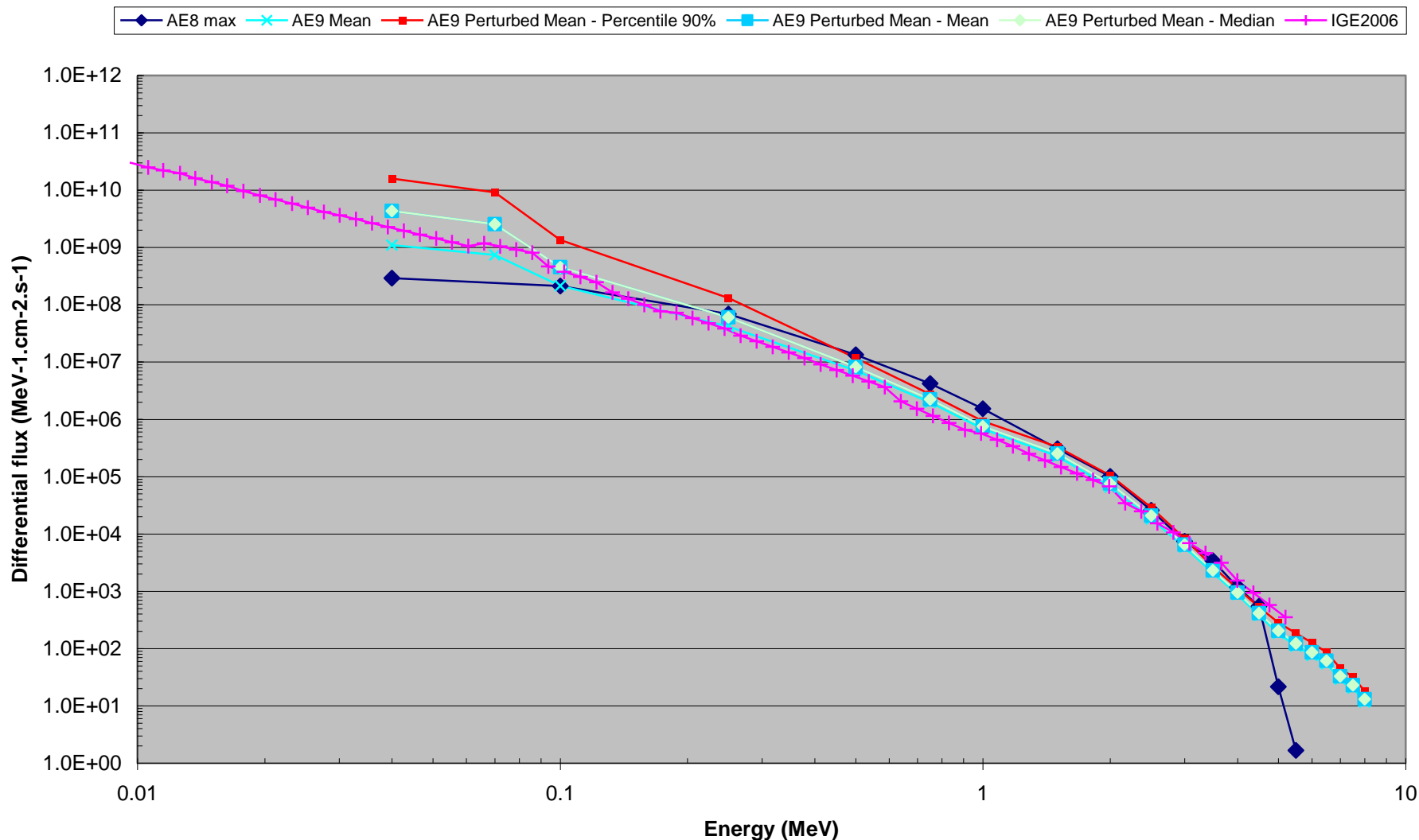

- Trapped protons for GEO (35 784 km, 0°, 160°W, 15y)

◆ AP8 min
 ◆ AP9 Mean
 ■ AP9 Perturbed Mean - Percentile 90%
 ■ AP9 Perturbed Mean - Mean
 ◆ AP9 Perturbed Mean - Median

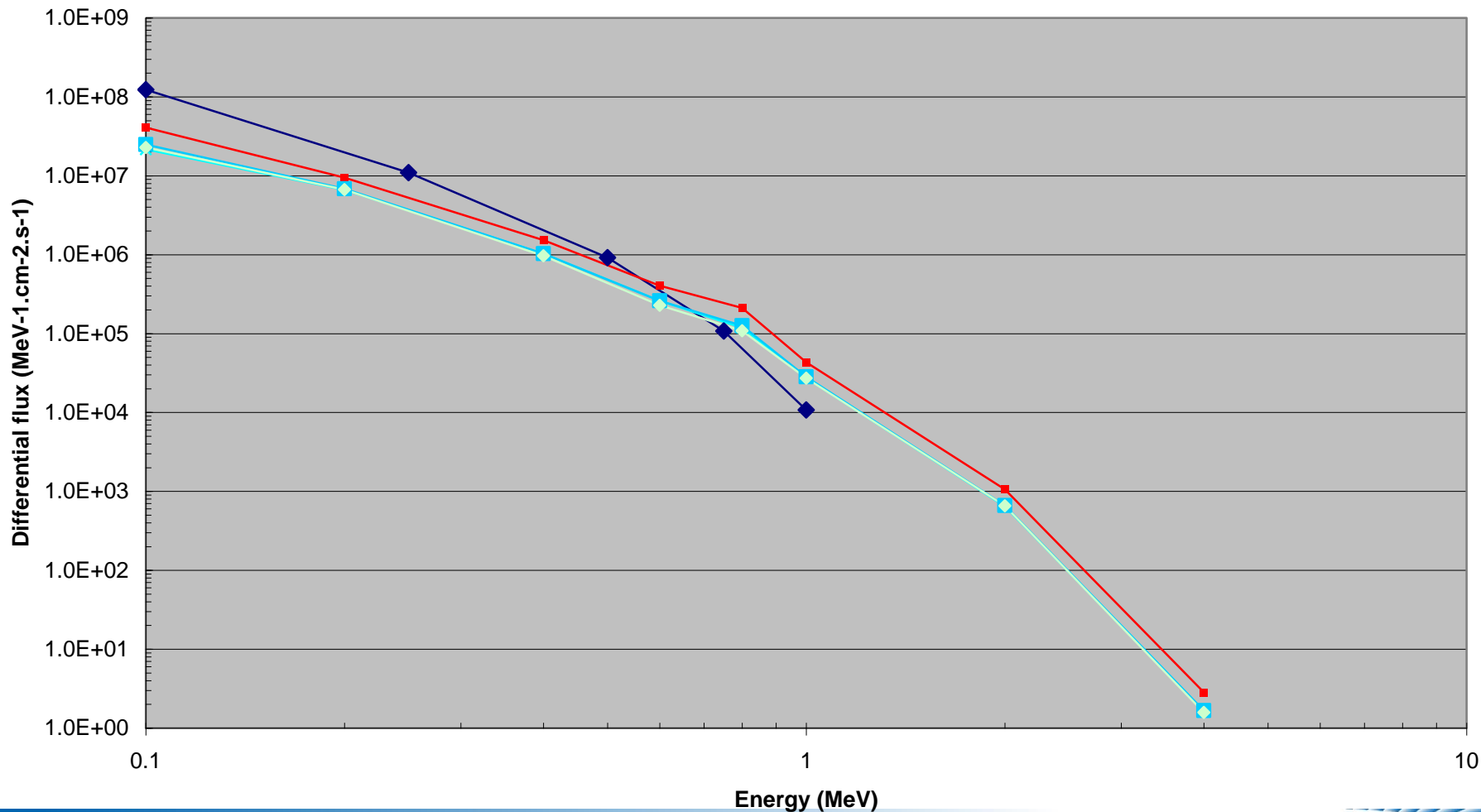

- Dose-depth curve for GEO (35 784 km, 0°, 160°W, 15y)

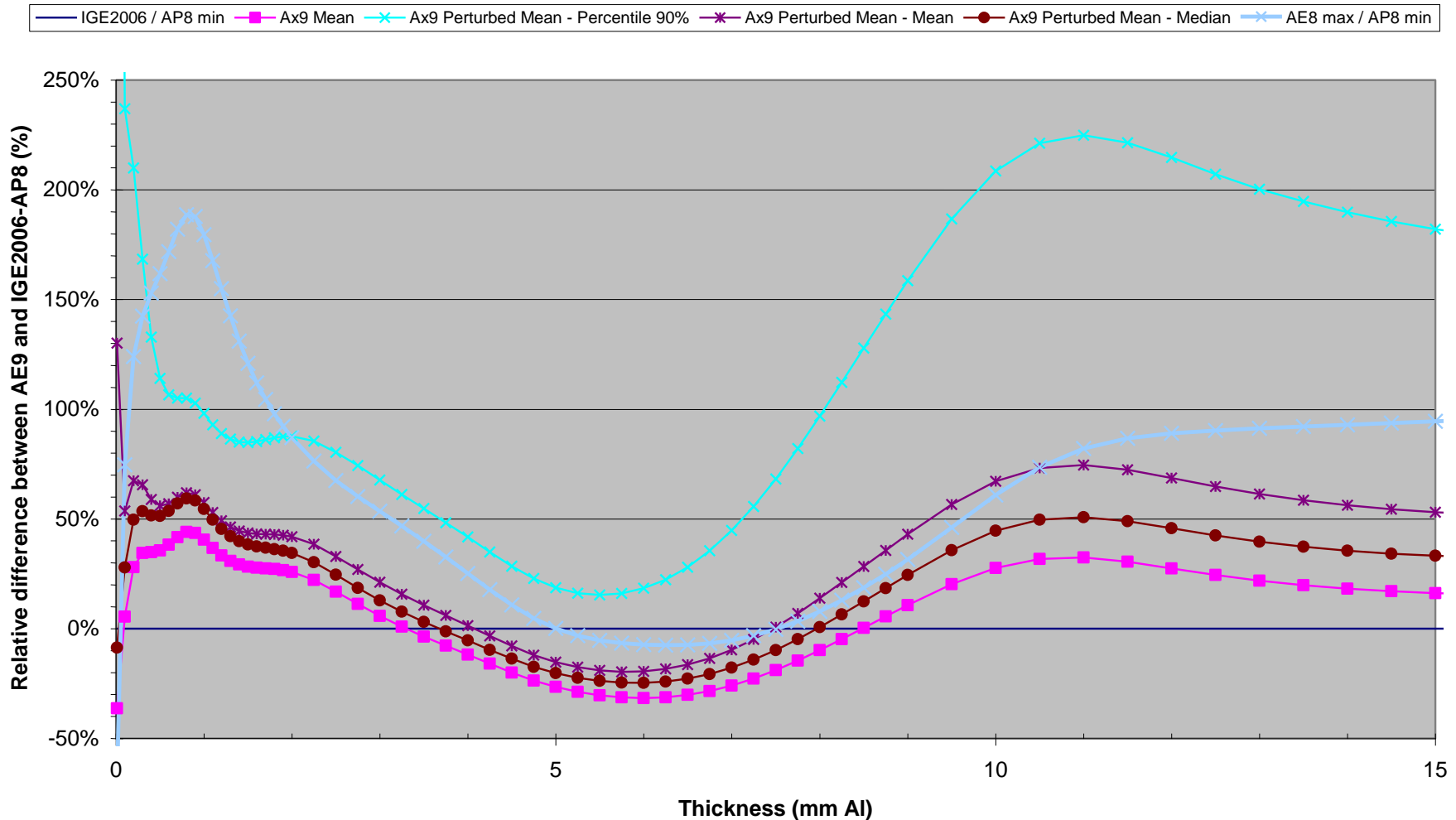

- Equivalent fluence-depth curve for GEO (35 784 km, 0°, 160°W, 15y)

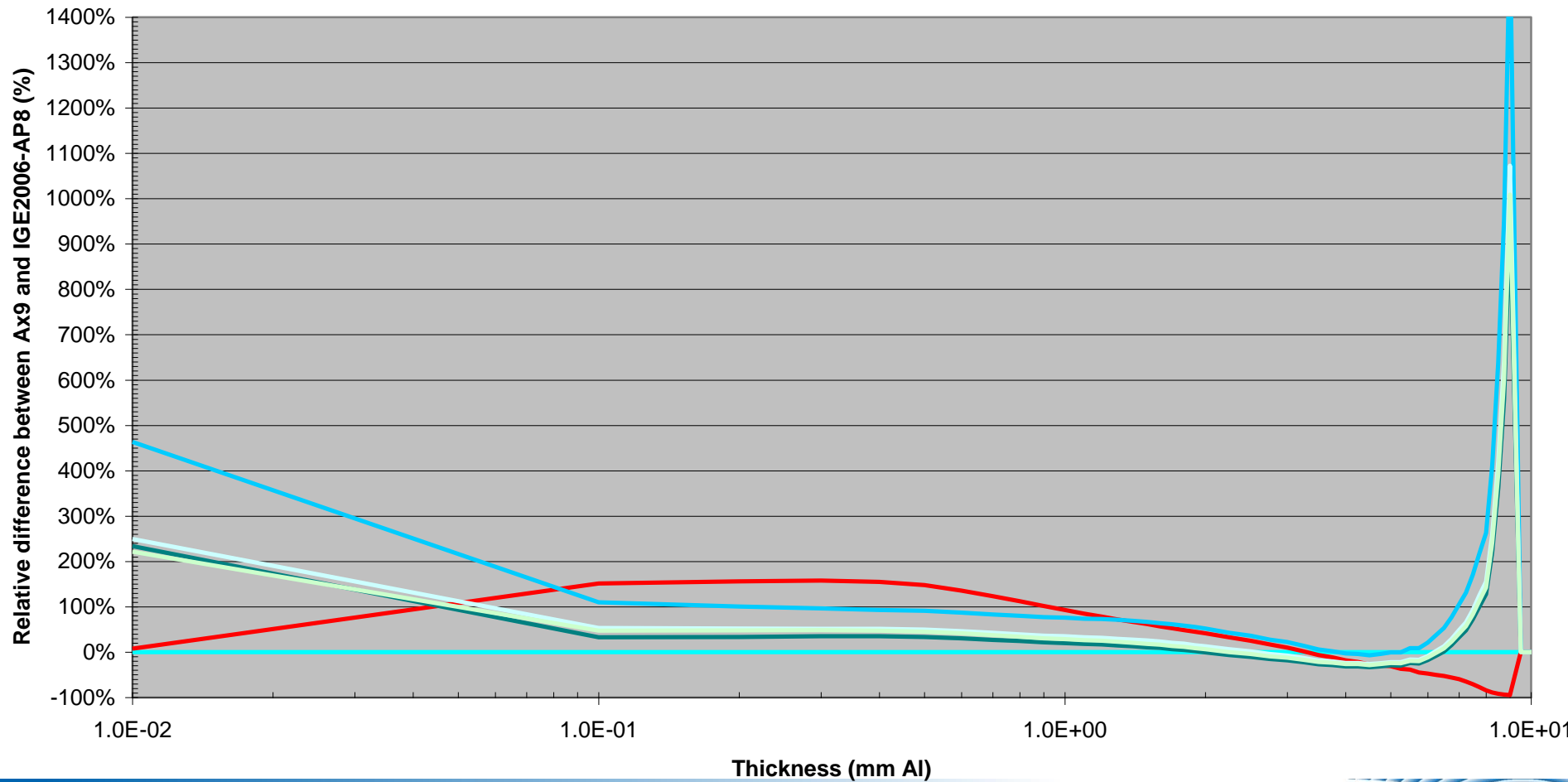
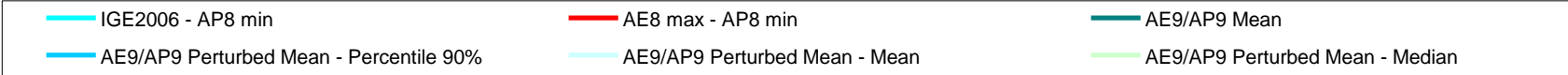

- Monte Carlo results for GEO (35 784 km, 0°, 160°W, 15y)

Detector	Device	Total Ionizing Dose by Monte Carlo			
		Relative difference Ax9/IGE2006&AP8 (%)			
		AE9 AP9 mean	AE9 AP9 PM mean	AE9 AP9 PM median	AE9 AP9 PM Perc. 90%
6	OPA683 - Z18	-14	5	-5	136
52	AD8011 - Z50	15	44	31	142
86	LT1415 - Z7	20	53	39	174
185	STPS3L60 - D16	15	34	27	114
272	K4S560432 - Z58	-20	-3	-12	59
284	IRFC360 - T12	25	50	35	127

Detector	Device	Total Non Ionizing Dose by Monte Carlo			
		Relative difference Ax9/IGE2006&AP8 (%)			
		AE9 AP9 mean	AE9 AP9 PM mean	AE9 AP9 PM median	AE9 AP9 PM Perc. 90%
6	OPA683 - Z18	-10	0,6	-3	35
52	AD8011 - Z50	62	81	72	151
86	LT1415 - Z7	92	115	104	203
185	STPS3L60 - D16	32	49	42	105
272	K4S560432 - Z58	-30	-22	-24	0,2
284	IRFC360 - T12	14	26	22	72

- Trapped electrons for EOR GTO 200 km

◆ AE8 max
 ▲ AE9 Mean
 ■ AE9 Perturbed Mean - Percentile 90%
 ◆ AE9 Perturbed Mean - Mean
 ■ AE9 Perturbed Mean - Median

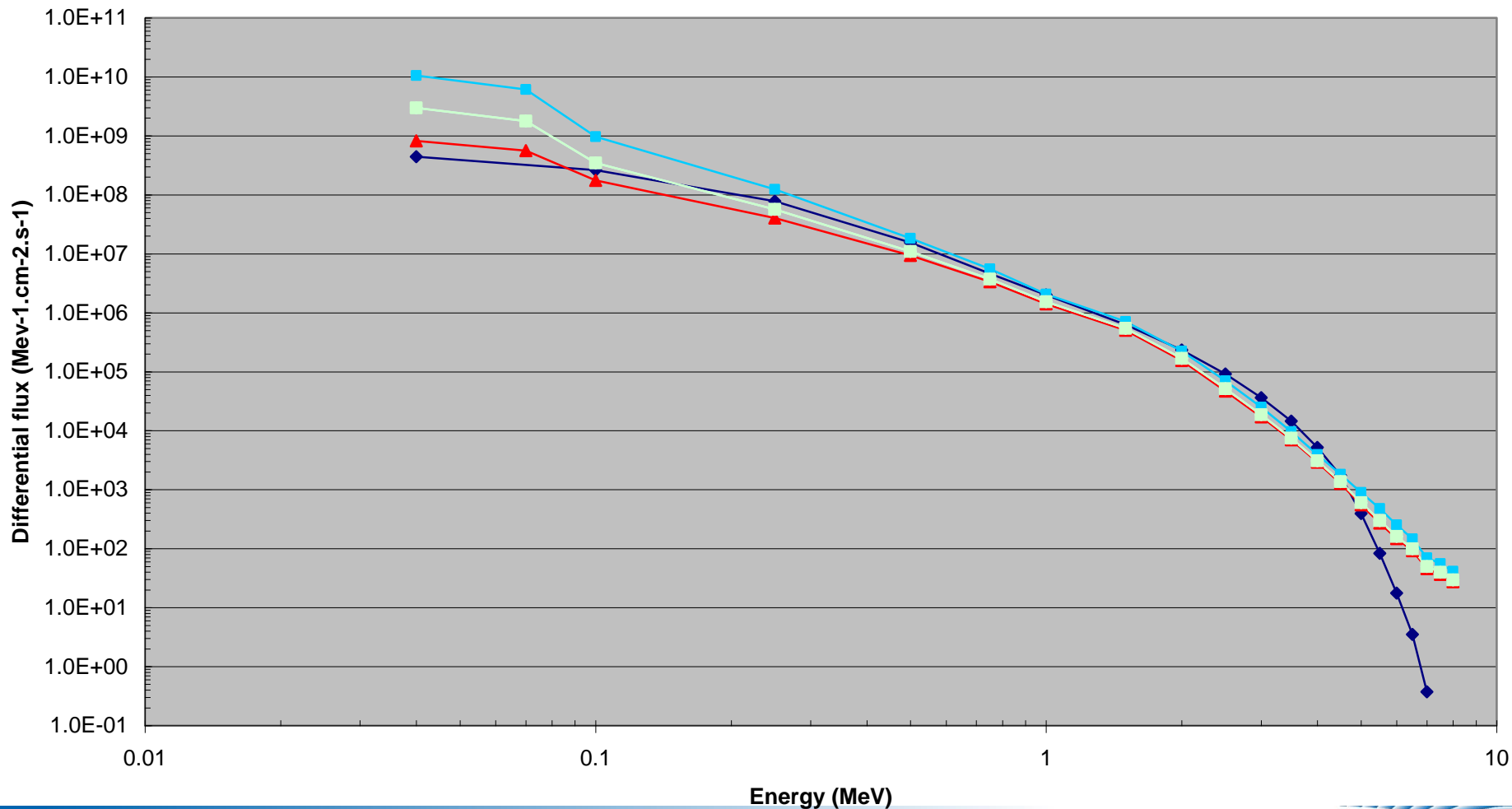

- Trapped protons for EOR GTO 200 km

◆ AP8 min
 ▲ AP9 Mean
 ✱ AP9 Perturbed Mean - Percentile 90%
 ● AP9 Perturbed Mean - Mean
 ✱ AP9 Perturbed Mean - Median

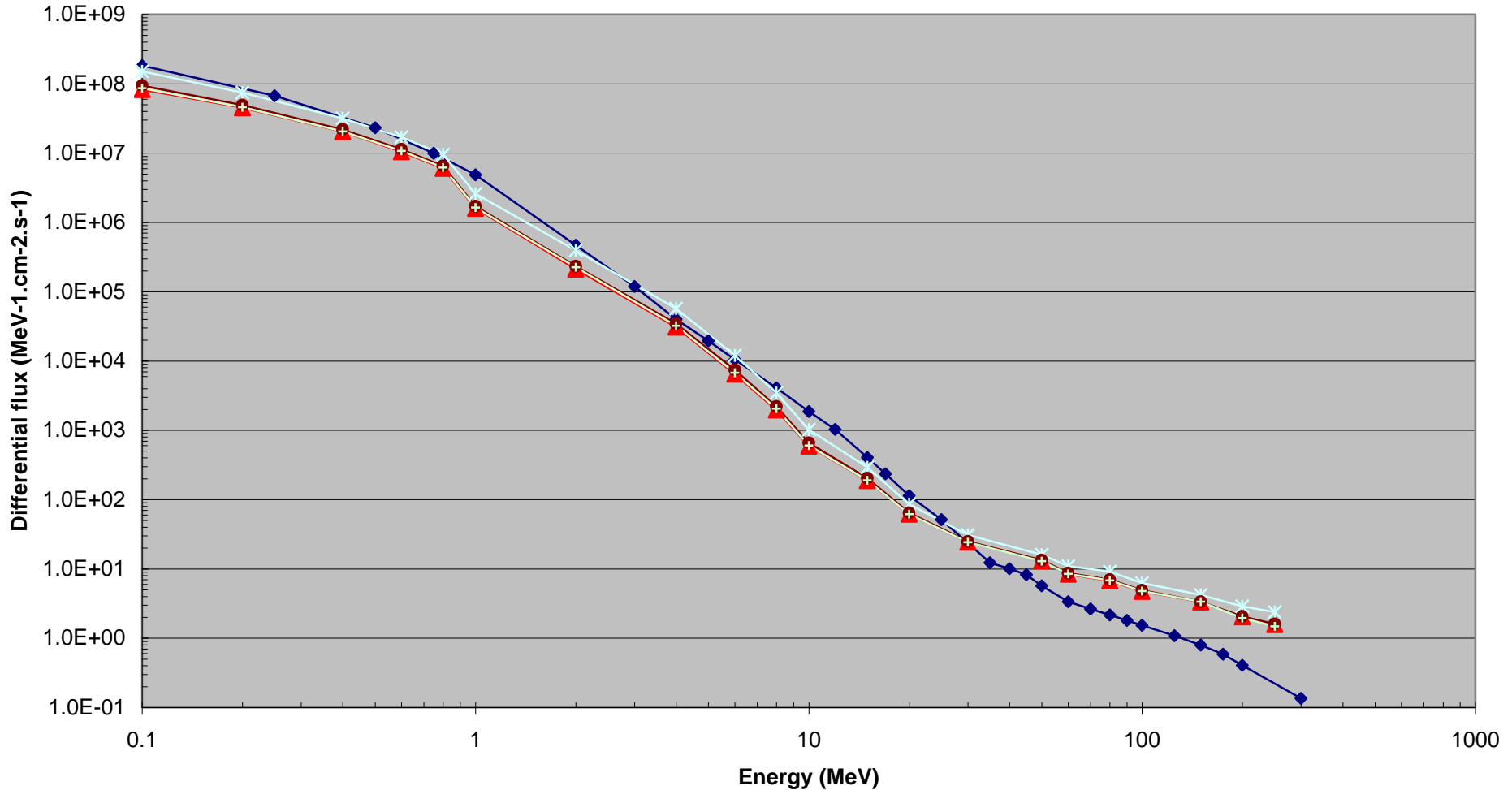

- Dose-depth curve for EOR GTO 200 km

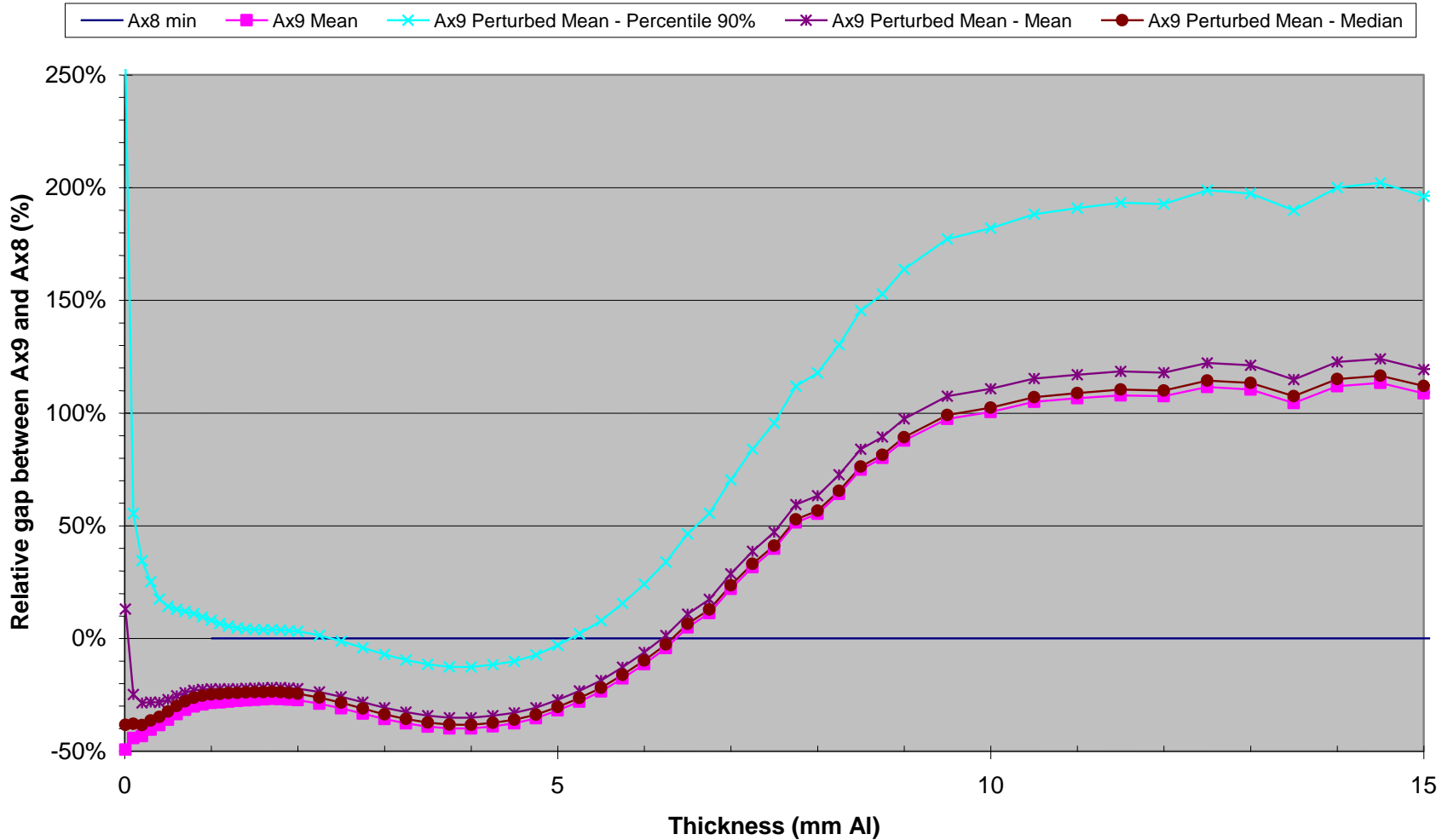

- Equivalent fluence-depth curve for EOR GTO 200 km

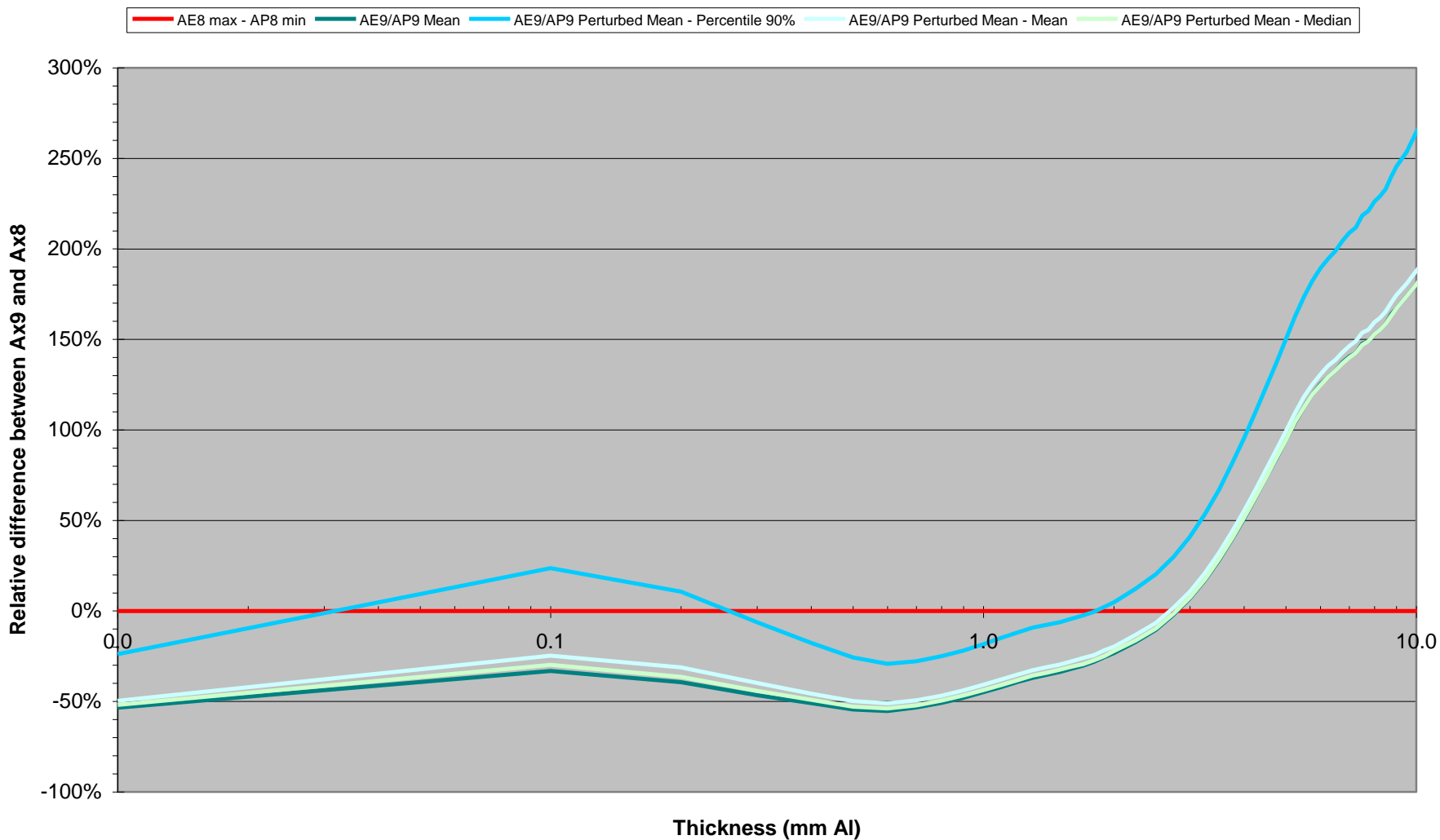

- Monte Carlo results for EOR GTO 200 km

Detector	Device	Total Ionizing Dose by Monte Carlo			
		Relative difference Ax9/Ax8 (%)			
		AE9 AP9 mean	AE9 AP9 PM mean	AE9 AP9 PM median	AE9 AP9 PM Perc. 90%
6	OPA683 - Z18	84	91	86	160
52	AD8011 - Z50	106	113	106	194
86	LT1415 - Z7	108	118	110	196
185	STPS3L60 - D16	141	149	142	229
272	K4S560432 - Z58	0.81	7	2	44
284	IRFC360 - T12	142	149	142	230

Detector	Device	Total Non Ionizing Dose by Monte Carlo			
		Relative difference Ax9/Ax8 (%)			
		AE9 AP9 mean	AE9 AP9 PM mean	AE9 AP9 PM median	AE9 AP9 PM Perc. 90%
6	OPA683 - Z18	220	229	221	324
52	AD8011 - Z50	245	252	244	358
86	LT1415 - Z7	248	256	248	363
185	STPS3L60 - D16	248	257	248	364
272	K4S560432 - Z58	154	161	155	234
284	IRFC360 - T12	254	262	253	371

- Transported fluxes for SEE rate calculations

		AP9 Mean / AP8	Ax9 MC Percentile 90% / AP8	Ax9 MC Mean / AP8	Ax9 MC Median / AP8
Energy (MeV)		Differential Flux (MeV-1.cm-2.s-1)			
3.705 mm Al					
LEO	10	3.9	6.1	4.0	3.9
	60	2.8	5.4	3.1	3.0
EOR GTO 200 km	10	1.0	1.7	1.0	1.0
	60	2.8	5.1	3.0	2.7
Sector file for detector 272 (lowest thickness, minimum = 4.18 mm Al)					
LEO	10	3.4	6.0	3.7	3.5
	60	2.6	5.0	2.8	2.7
EOR GTO 200 km	10	1.8	3.1	1.9	1.7
	60	3.1	6.2	3.5	3.0
Sector file for detector 284 (highest thickness)					
LEO	10	2.6	5.0	2.9	2.7
	60	2.4	4.4	2.6	2.4
EOR GTO 200 km	10	3.0	5.8	3.4	2.9
	60	3.4	7.0	3.9	3.2

* flux calculation with MC for EOR GTO 200 km (20 000 orbit points) takes ~11 hours!

- Flux comparison results between the different models depend on energy -> differences in dose & equivalent fluence depth curves depend on shielding
- Important differences at component level analysis, results depend on the shielding especially for GEO and EOR GTO.
- Mean, PM mean and PM median give similar results, however the PM 90% is largely above.
- Factor of 3-7 on transported 60 MeV proton fluxes that can have an impact on SEE rates.
- Time needed for the flux calculation with Ax9 MC is of several hours instead of several seconds for the currently used models.

- Ax9 models are still evolving – v1.35.001 release in January 2017
- Known issues and limitations especially for LEO orbits:
 - ▶ protons: no solar cycle flux dependance, high flux uncertainty
 - ▶ protons & electrons: significant uncertainty on flux gradients
- Which model options should be used by engineers?
- Important differences have been observed on comparison results for radiation analysis. What do in-flight measurements show? -> see next presentation!