



# PERIOD

PERASPERA In-Orbit Demonstration

**PERIOD – PERASPERA In-Orbit Demonstrator  
for validating core on-orbit manufacturing, assembly and  
servicing operations.**

Dr.-Ing. Stéphane Estable (Airbus)

Annelies Ampe, Apostolos Chamos, Gwenaelle Aridon, Daniel Silveira, Francisco  
Javier Colmenero, Isabel Soto, Jeremi Gancet, Mark Shilton, Marko Jankovic

ESA's Clean Space Industry Days (CSID) 2021

20-24 September 2021

This project has received funding from the European Union's Horizon 2020 Research and Innovation programme  
under Grant Agreement No 101004151





# Consortium

European Union's Horizon 2020  
Research and Innovation programme

# PERIOD



## AIRBUS

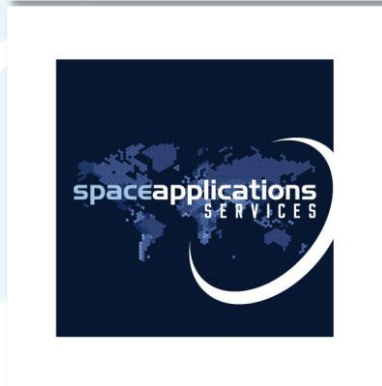



# PERIOD Demonstration main objective

Build a satellite in orbit from a kit with a robotic system.

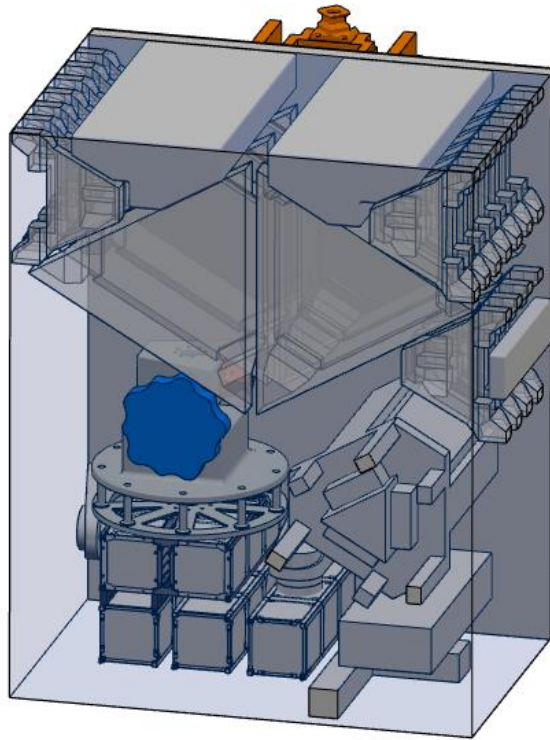

From a satellite kit...

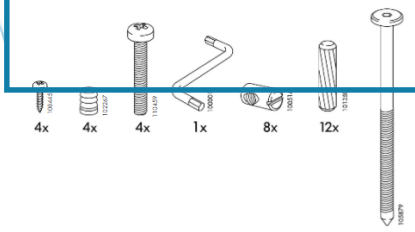
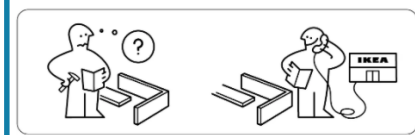
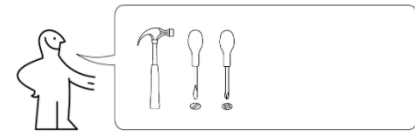

*Orbital  
Factory*

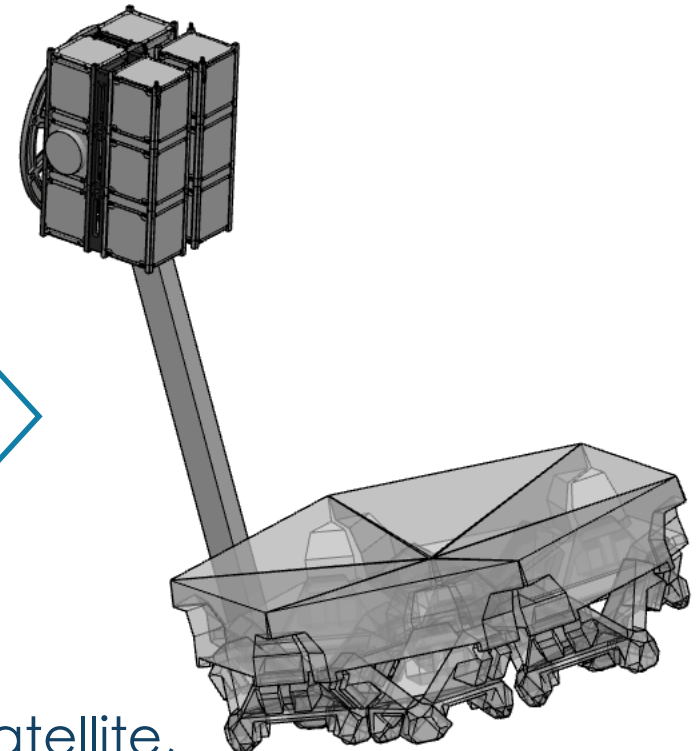

...to a functioning assembled satellite,

including inspection, reconfiguration, attachment, refuelling.





# ISMA Demonstrations



The selected demonstrations focus on the applications with the expected highest economic values.

Selected ISMA demonstrations:

1. Assembly of antenna reflector.
2. Assembly of complete satellite from building blocks equipped with SI including verification.
3. Reconfiguration of the satellite payload for system upgrade.
4. Inspection of the assembled satellite.
5. Refuelling with capture/attachment.

**ISMA: In-Space Services, Assembly and Manufacturing**

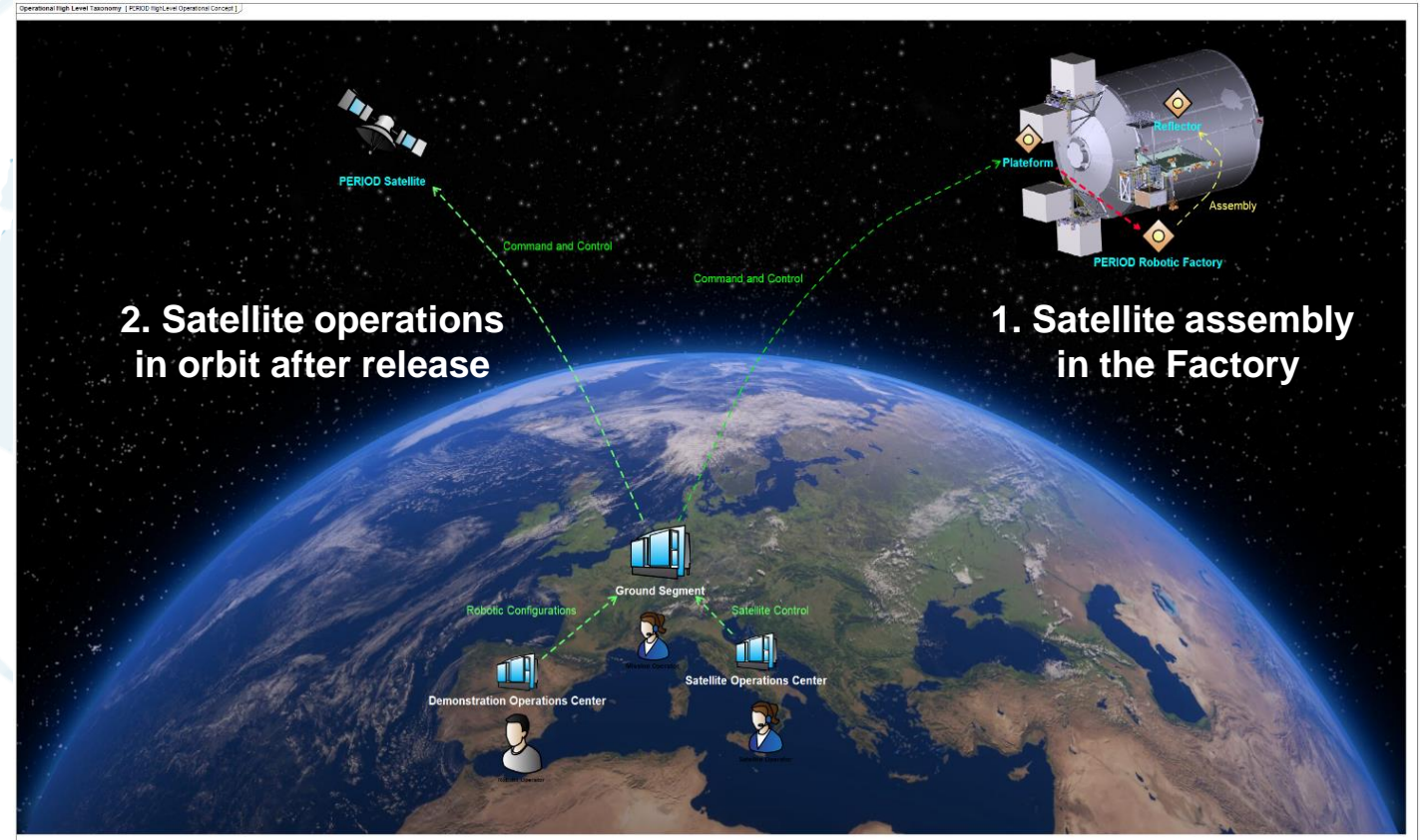



# ISMA Factory accommodation

Focus budget spending on elements providing highest value for innovation, and preparation of future ecosystem.



Integration on the ISS / Columbus external commercial platform Bartolomeo from Airbus.

<https://www.airbus.com/space/space-infrastructures/bartolomeo.html>

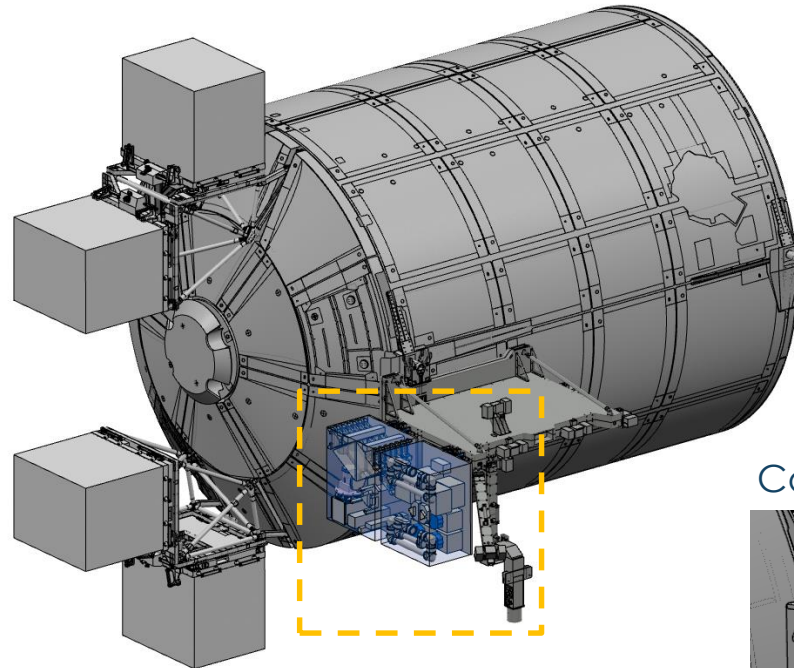

Configuration 1 for Satellite Assembly

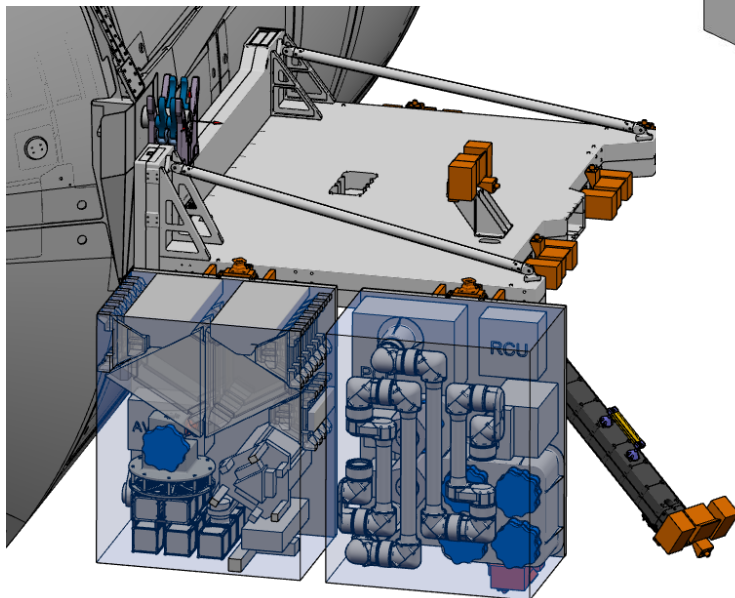

Configuration 2 for Capture & Refueling

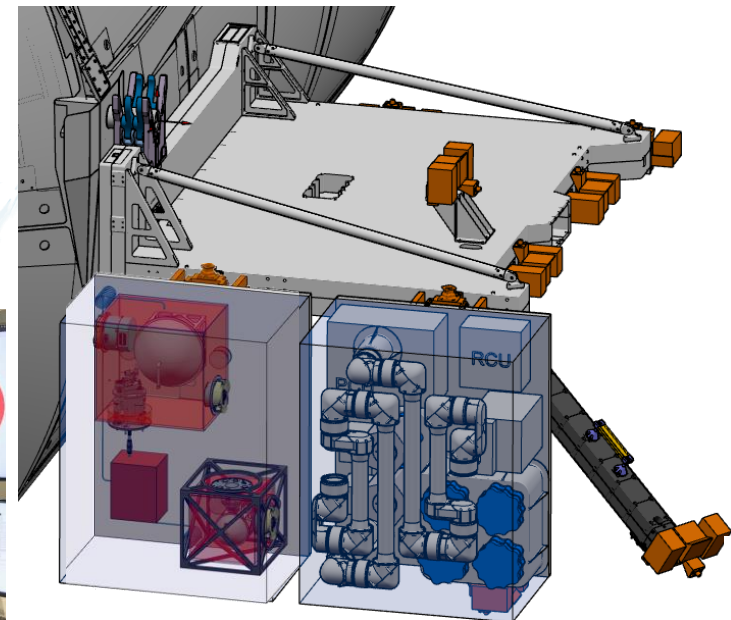

Factory Control Station





# ISMA Factory design concept

On-going phase A/B1 until 12/2022 to define the mission and system concepts.

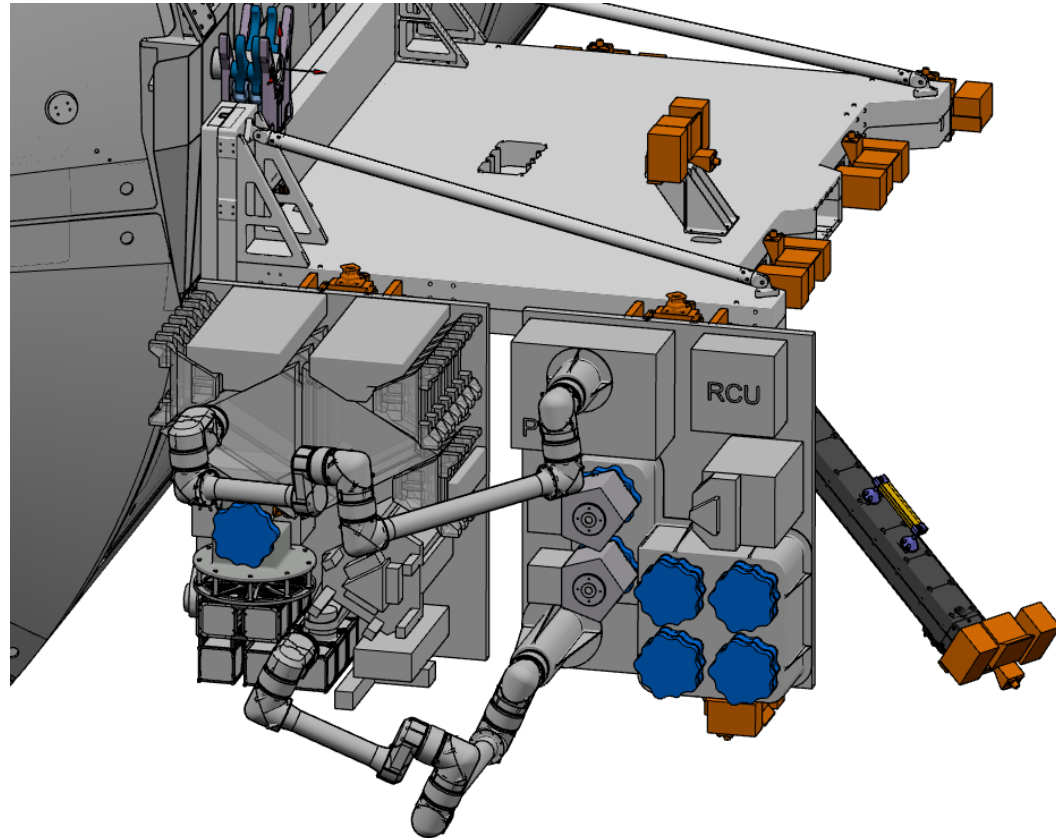

Satellite Kit Box

Factory box

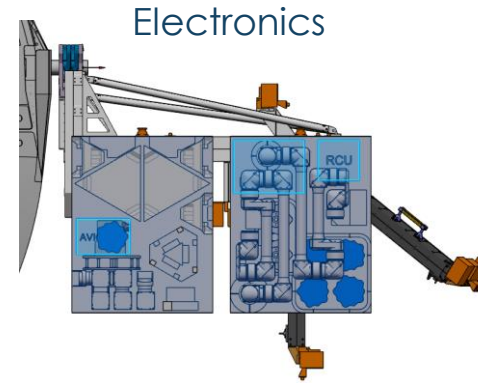

Electronics

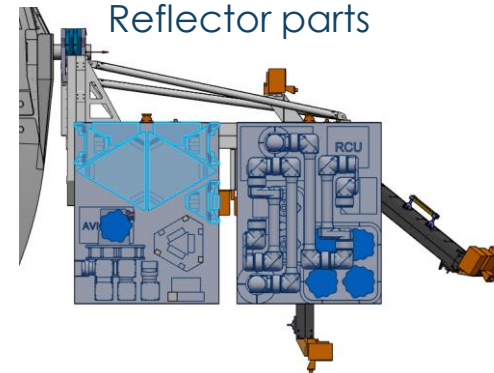

Reflector parts

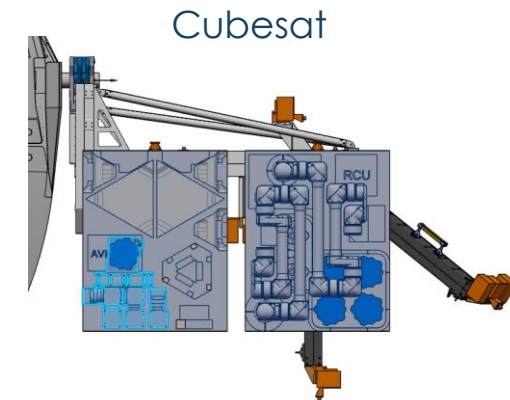

Cubesat

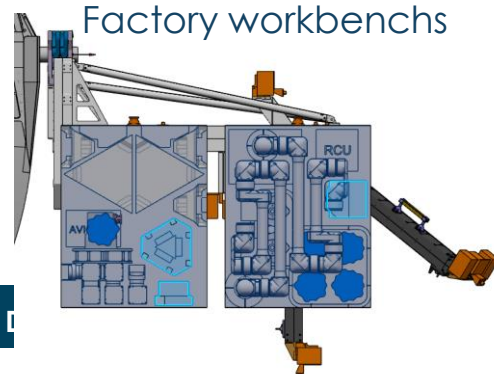

Factory workbenches

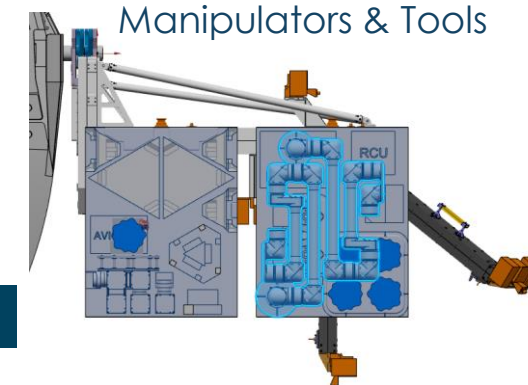

Manipulators & Tools



# PERIOD Mission Phases

The in-orbit demonstration is planned as early as 2026 to validate the core ISMA capabilities and technologies.

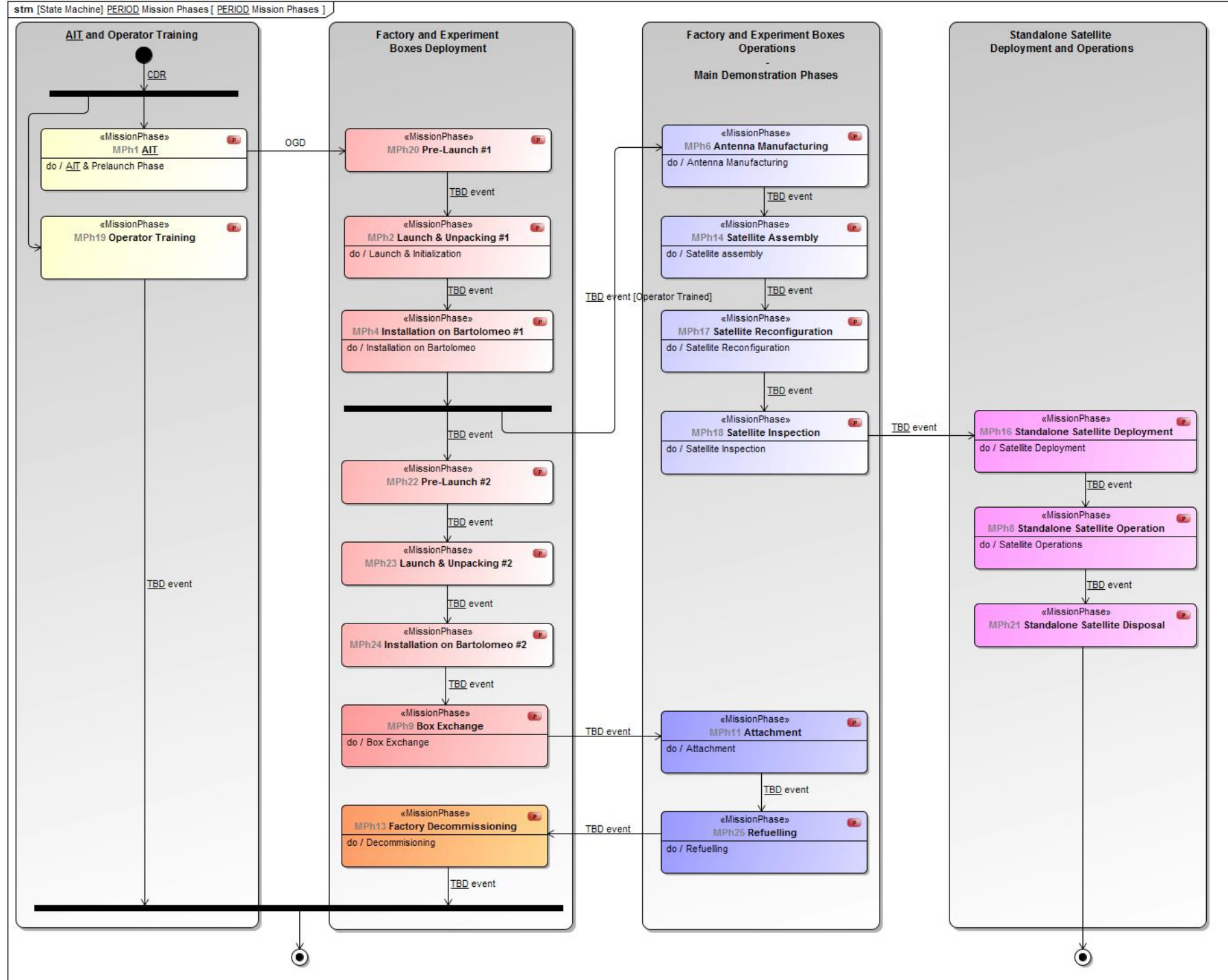



# PERIOD Mission Statement



PERIOD will provide independent European ISMA capabilities.

Demonstrating ISMA capabilities, the PERIOD mission will initiate the transformation of the lifecycle of space systems toward higher value, higher system capacities, higher resilience and lower capital expense, and toward independent European capabilities allowing Europe building the future orbital infrastructure and being competitive on the ISMA market.

**Higher value** means the part of the total mass of the space asset dedicated to the payload generating revenues is higher. This is made possible by the system assembly done in micro-gravity, thus getting rid of a heavy structure required to survive the launch phase when the system is already integrated on Earth.

**Higher system capacities** will be provided by larger reflectors for communication or telescope and larger hub to integrate and operate numerous payloads. As the constraint of the launch volume limitation disappears when structures are assembled while in orbit, new and never seen dimensions for space assets can be envisioned.

**Higher resilience** comes from the built-in servicing capabilities of the spacecraft. As the spacecraft are designed to be assembled in orbit, the refurbishment and repair of system units can be reliably performed.

**Lower capital expense** (Capex) for providing additional and new capacities is made possible as not the overall spacecraft needs to be replaced on a regular basis but potentially only the parts related to the payload.







# Unlocked Economic Value



ISMA will open a large market relying on a new paradigm.

## Technological capability

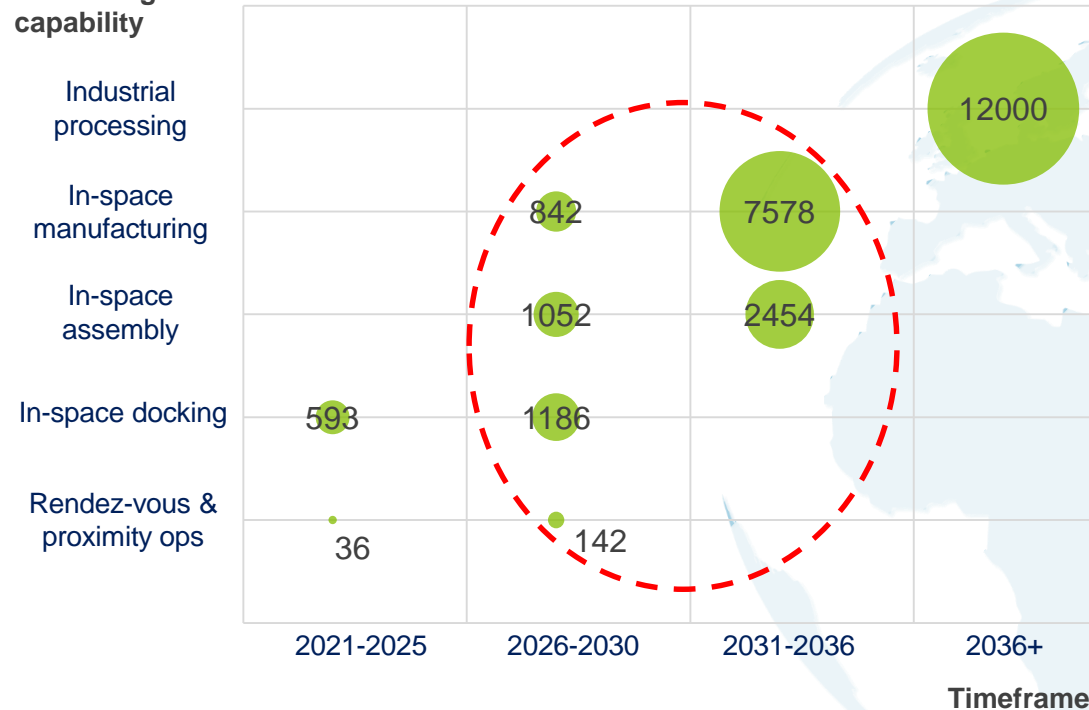

Max. economic value of €26bn would be unlocked via identified technologies and applications, considering revenues generated in the first 10 years after 1st operational mission of each application.  
 €14 bn would be the value when excluding missions with 1st operation beyond 2035.

### 2021-2025

- Revenues from services such as **life extension, relocation**/"last mile delivery", **close inspection** and active debris removal.

### 2026-2030

- In addition to the existing ones, new servicing missions like **rescue/repair and refuelling** or installation of propulsion modules
- New missions enabled via in-space assembly, possibly assembly of **antenna reflectors** (could be stackable), **solar panels** and booms which could also fly in cubesats or small sat missions.
- Automatized assembly, inspection and repair of the **Lunar Gateway** could see an application in Human Spaceflight.

### 2031-2036

- In-space assembly missions like **P/L upgrade and large antenna reflectors** generate most of the value, as well as autom. maintenance of manned space stations.
- Also first missions featuring **in-space additive manufacturing** for space and for Earth could appear,

### 2036+

- New applications like **GEO "Hubs"**, very **large diameter reflectors** (+18m), Lunar ISRU and **space-based power generation** could become very large markets.





# Transition into the new paradigm

Assemble, test and verify spacecraft in orbit to achieve new ambitious goals.

- State of current space infrastructure brings **lots of limitations on the space assets** like limited size, low reuse, oversized design, over quality, no repair, no maintenance, high time to market.
- **Set new ambitious goals** toward higher value, enhanced functionalities and capacities, higher resilience, lower capital expense and new products.
- New desired state of future space infrastructure relies on **building blocks, standard interfaces, design optimized for microgravity**, lower mass / higher value, refurbishment, large structures, lower capex, lower time to market.

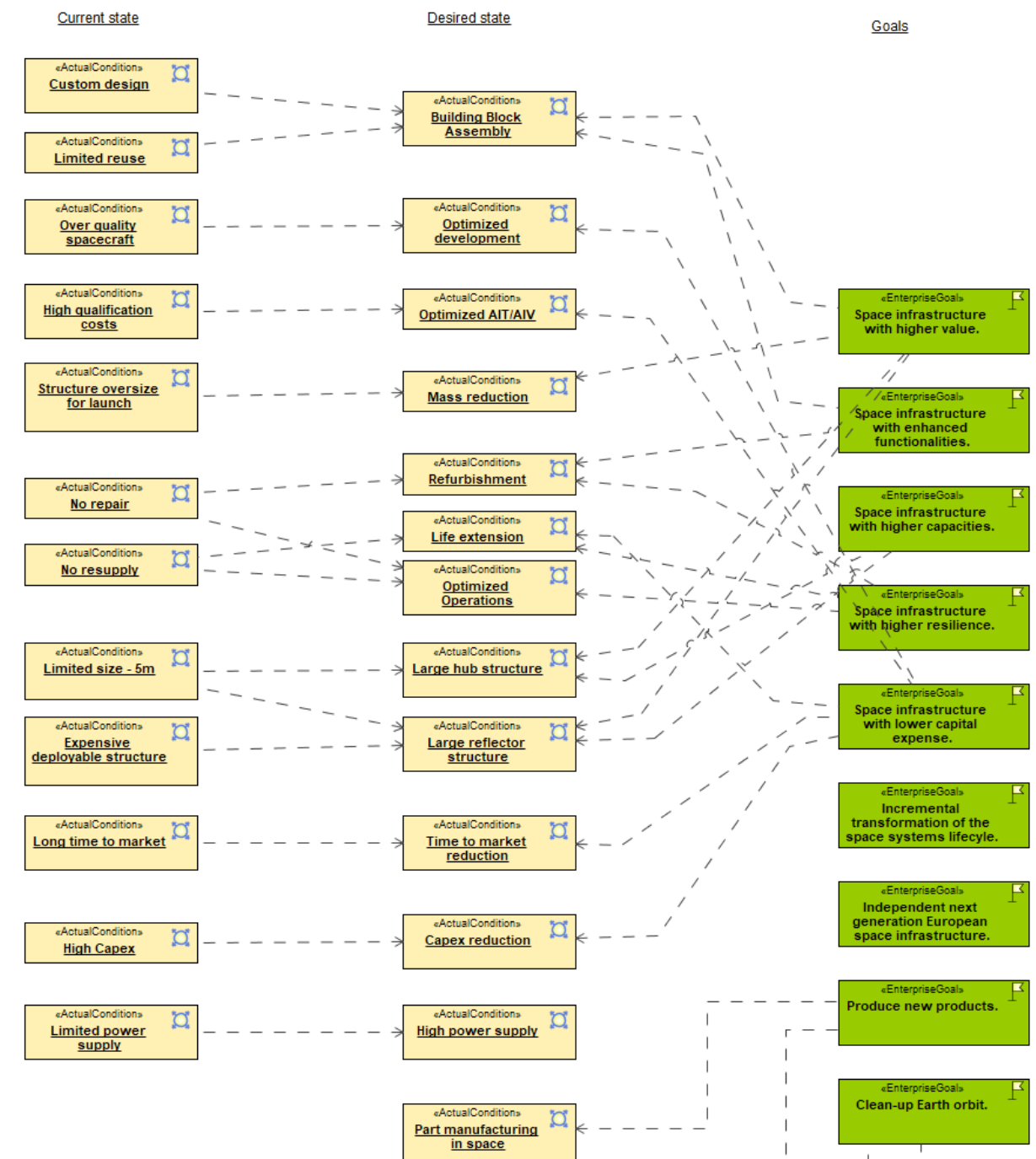



# Evolution of the lifecycle of space assets



The smooth transition will go through a progressive transformation of the lifecycle of space systems.

- Phases of the lifecycle will progressively be **transferred for their operations in orbit** to overcome the limitations of current space systems.
- As space systems are integrated and qualified in orbit, their **maintenance operations are already fully integrated in their design** for a robust and viable implementation.

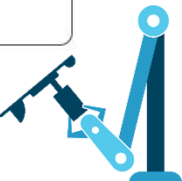
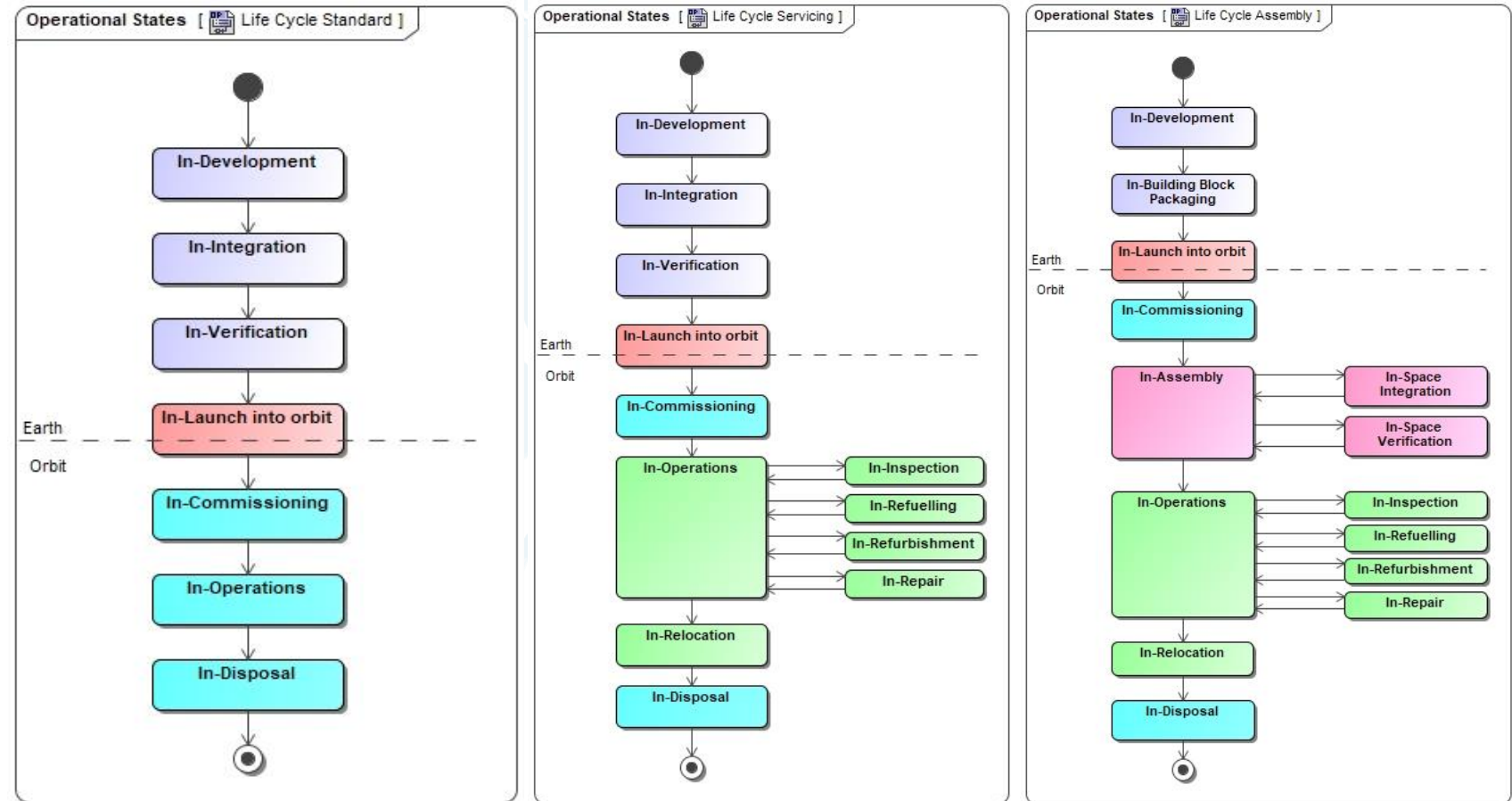



# Uncertain ISMA context during the transition

ISMA context is uncertain w.r.t. communication market, launcher price impacts and regulations.

- **Lower launch costs** can help prove out ISMA technologies but also make it **cheaper to launch replacement satellites** rather than repair them.
- **Growth in space-based communications**, if in LEO, may **increase the need for deorbit services**. If in GEO, it may drive the case for other ISMA services (repair, replace parts, assembly).
- **Dual-use regulations** would **inhibit the commercial development of servicing capabilities**, while debris removal and EOL regulations would provide the business case for relocation operators.





# Technology push to new ISMA capabilities



Development of H2020 PERASPERA SRC Common Building Blocks for robust robotic operations in space environment.

- The SRC goal is to **increase the maturity of space robotics technologies** and demonstrate them in the 2023-2026 time framework with sizeable **demonstration** missions.
- ISMA **capabilities needed to implement the new states** w.r.t. assembly, reconfiguration, inspection, verification and refuelling.
- PERIOD will **validate ISMA capabilities** required to reach the new desired space infrastructure states and prepare the future market in a smooth transition.

**SRC: Strategic Research Cluster**

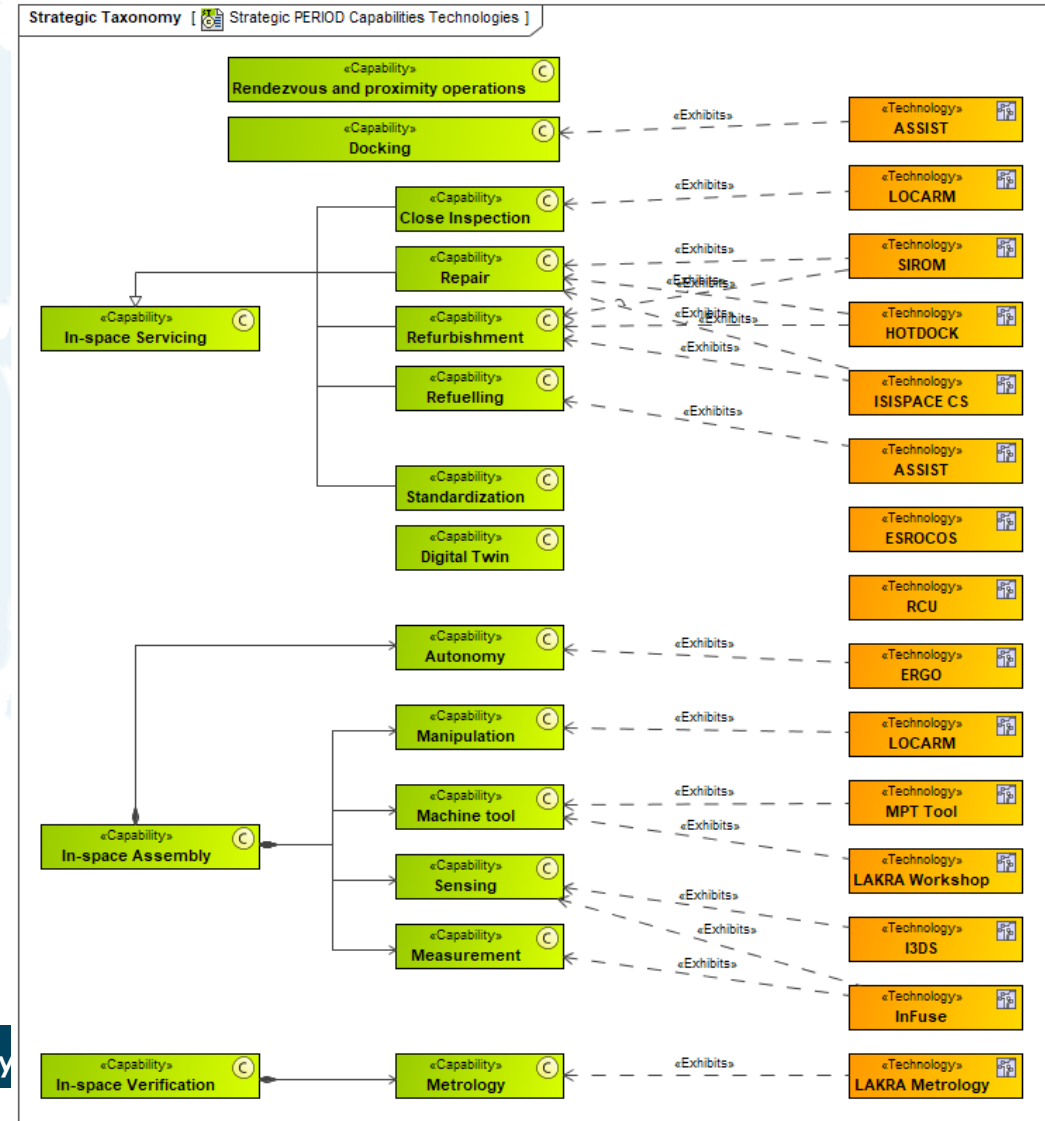



# PERIOD Technology development



Development to TRL5 of SRC Common Building Blocks for preliminary integration and testing in breadboard.

## ESROCOS

European Space Robotics Control and Operating System

<https://www.h2020-esroc.eu>

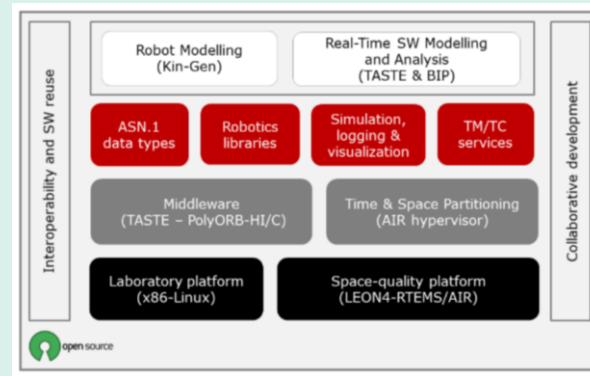

Open-source framework for space robotics software

## ERGO

European Robotic Goal-Oriented Autonomous Controller

<https://www.h2020-ergo.eu>

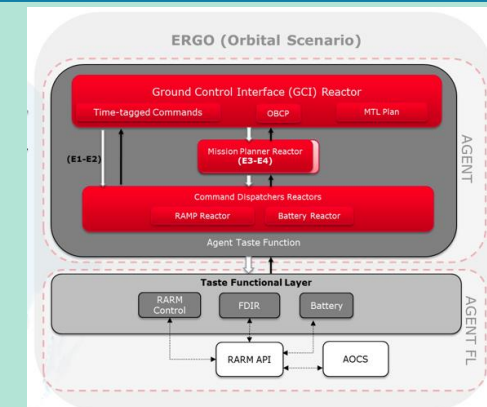

Autonomous Framework for robotic operations

## InFuse

Data Fusion For Space Robotics

<https://www.h2020-infuse.eu/>



Model-based and marker-based pose estimation

## I3DS

Integrated 3D Robotics Sensors Suite

<https://cordis.europa.eu/project/id/730118>

Sensor management and pre-processing

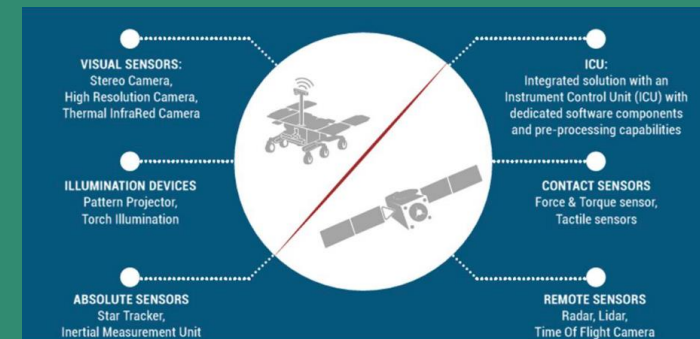



# Standard Interconnect - SI

Benchmarking of 3 Standard Interconnects for evaluation.

## SIROM

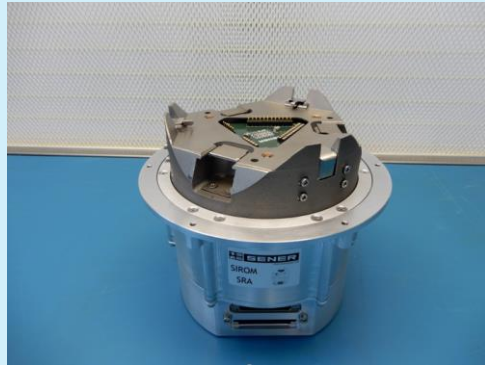

SIROM



SIROM in test configuration

(credit: SENER Aeroespacial)

H2020 SRC Building Block

## HOTDOCK

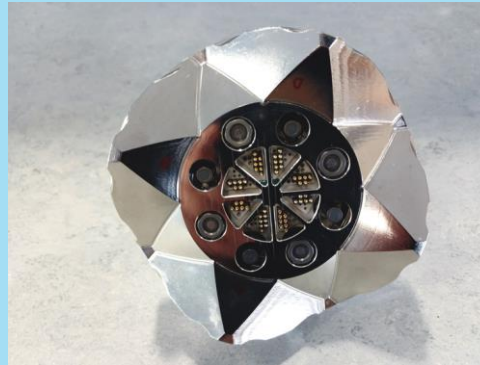

HOTDOCK – passive part-  
used in MOSAR



HOTDOCK – active part-  
used in MOSAR

(credit: Space Applications Services)

H2020 SRC Building Block

## iSSI®

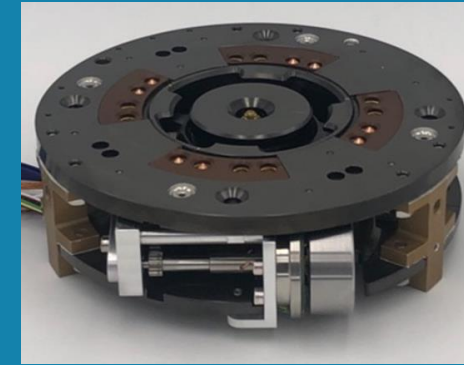

iSSI® SPACE ACTIVE

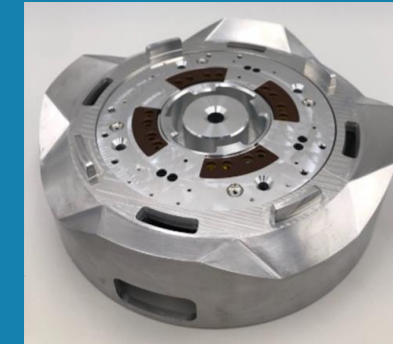

w FormFit Add-On Module

(credit: iBOSS GmbH)





# Robotics development at Airbus for ISMA



Maturation of complementary technologies for ISMA and exploration.

## LOCARM / ViSCoL / RCDVF

Low Cost Arm for space applications including visual servoing and impedance control



Enabling technology to support new applications and Services including ISMA and Active Debris Removal (ADR).

**AIRBUS**

## MANTOS / STARLIT

Robotic tools for ISMA operations



Airbus facility enabling an end-to-end testing of assembly operations with robotic tools and image processing (DLR co-funding).

**AIRBUS**

## LAKRA

Large Antenna Kit Robotic Assembly



Airbus facility enabling an end-to-end manufacturing process using virtual reality to avoid collisions by simulating the in-orbit environment.

**AIRBUS**







# PERIOD expected impacts

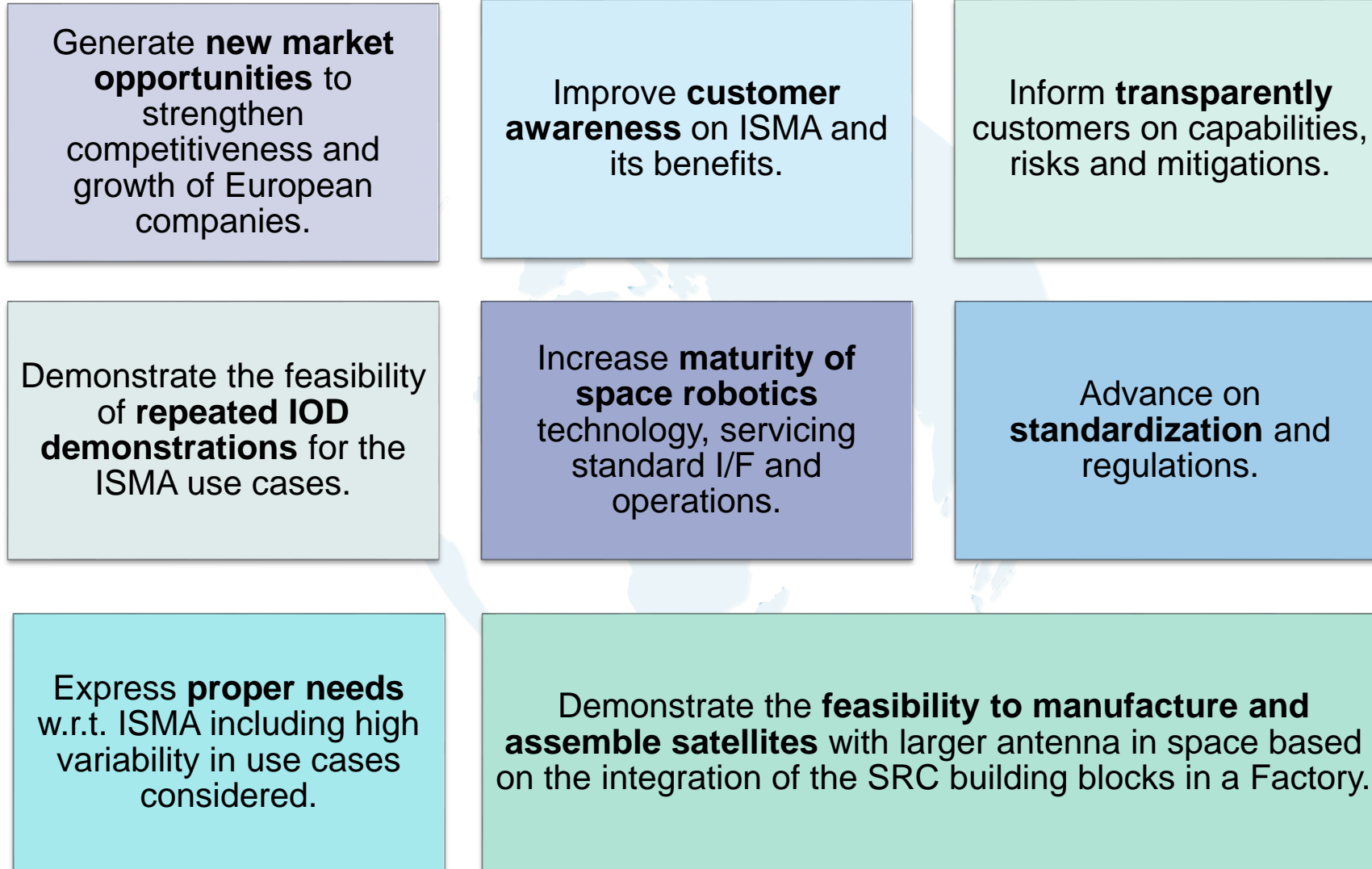



# Follow PERIOD in the social media!

Regular posts/tweets on social media based on existing progress/material/news.



## LinkedIn

<https://www.linkedin.com/company/period-project/>

## twitter

[https://twitter.com/PERIOD\\_H2020](https://twitter.com/PERIOD_H2020)

## Website

<https://period-h2020.eu/>

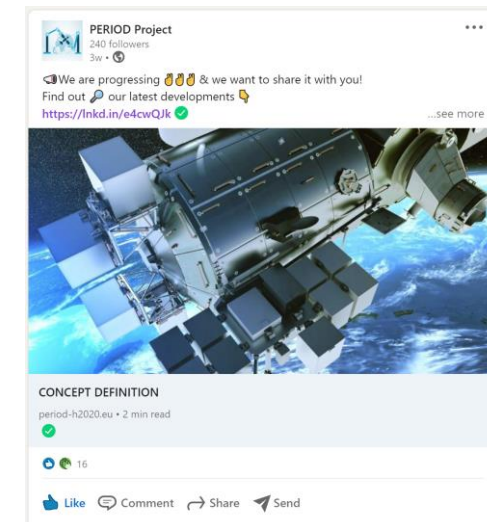
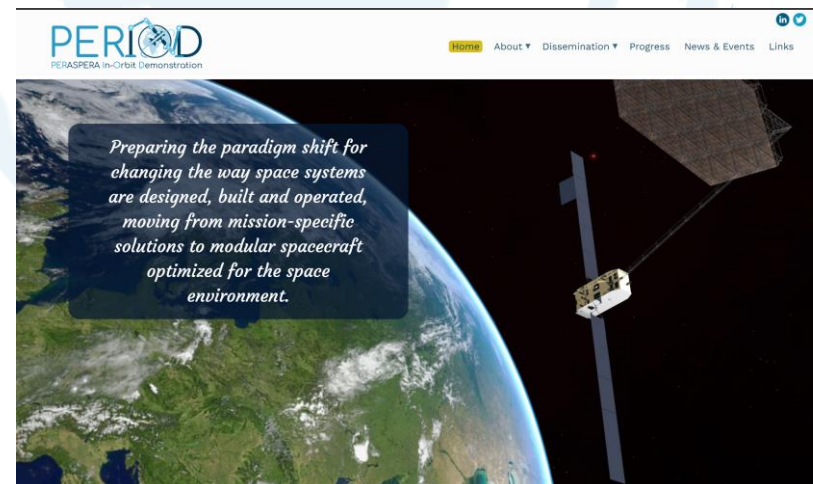
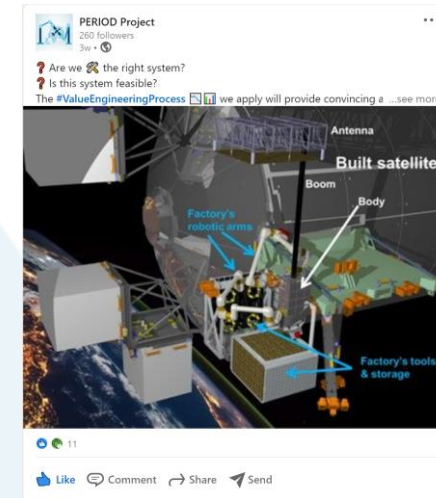

---

Thank you!



The research leading to these results has received funding from the European Union's Horizon 2020 Research and Innovation programme under Grant Agreement No 101004151.

This document and all information contained herein is the sole property of the PERIOD Consortium or the company referred to in the slides. It may contain information subject to Intellectual Property Rights. No Intellectual Property Rights are granted by the delivery of this document or the disclosure of its content. Reproduction or circulation of this document to any third party is prohibited without the written consent of the author(s).

The statements made herein do not necessarily have the consent or agreement of the PERIOD Consortium and represent the opinion and findings of the author(s). The dissemination and confidentiality rules as defined in the Grant Agreement apply to this document.



