

Heat Flux Measurement on Spinning Test Models in Hypersonics

S. Willems, A. Weiss, P. Seltner, T. Schleutker, A. Gülhan

*Supersonic and Hypersonic Technologies Department
Institute of Aerodynamics and Flow Technology
German Aerospace Center (DLR)*



Knowledge for Tomorrow



Content

- Motivation
- Experimental set-up
- Results (preview)
- Conclusion



Motivation

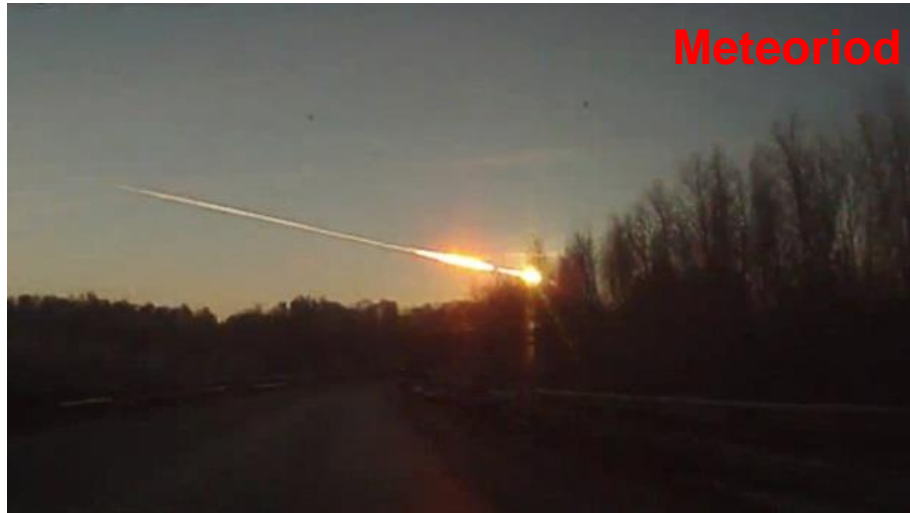

Entry of Chelyabinsk meteoroid¹



Propellant tank, Delta rocket²



Reentry of MIR space station³

- Uncontrolled re-entry
- Damage to persons / property
- Where? When? What?
- Ablation / demise
- Rotation / tumbling



Set-up - sketch

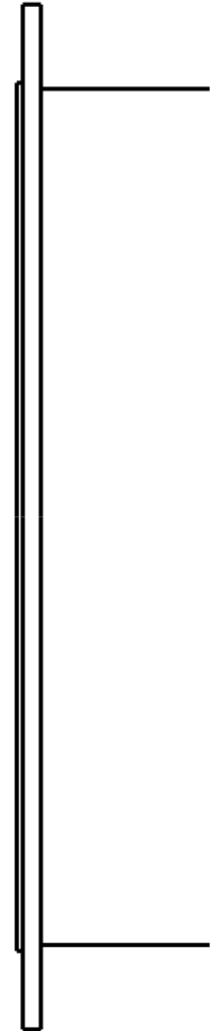
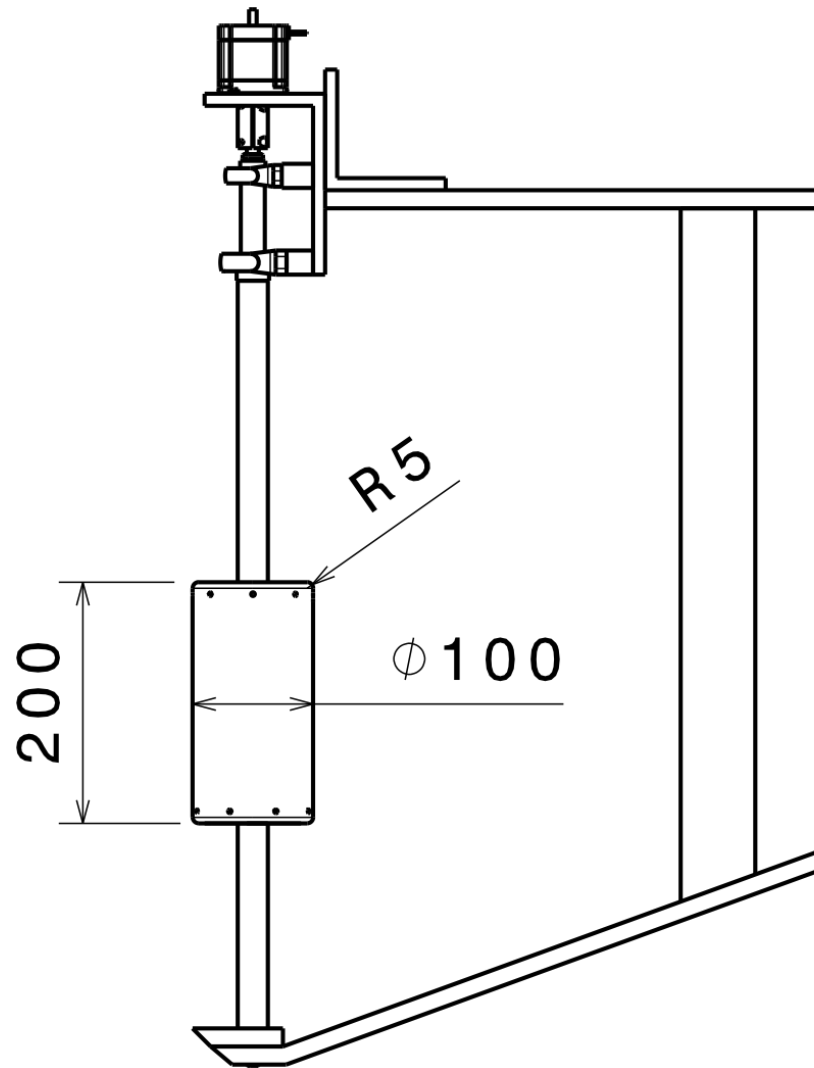
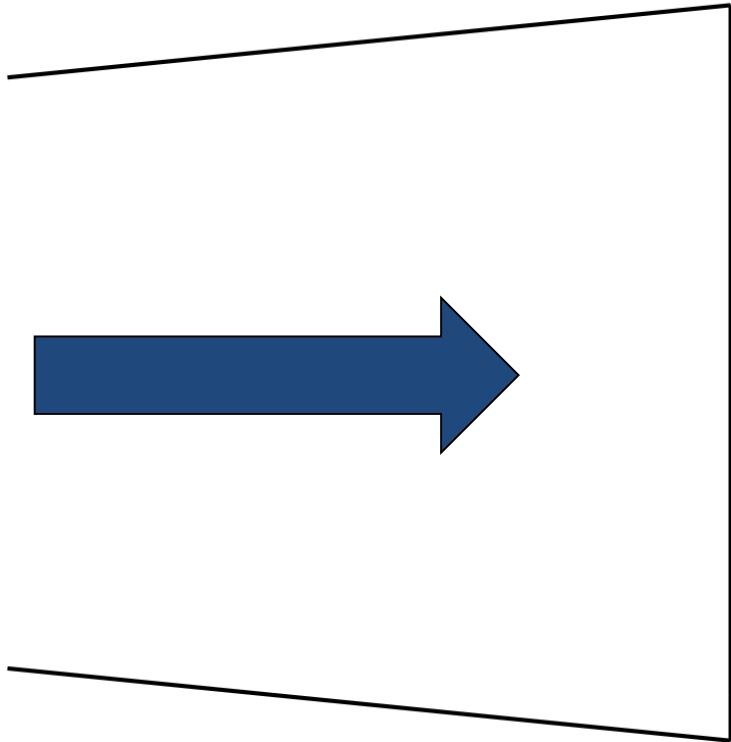

Hypersonic test section (H2K) – test conditions

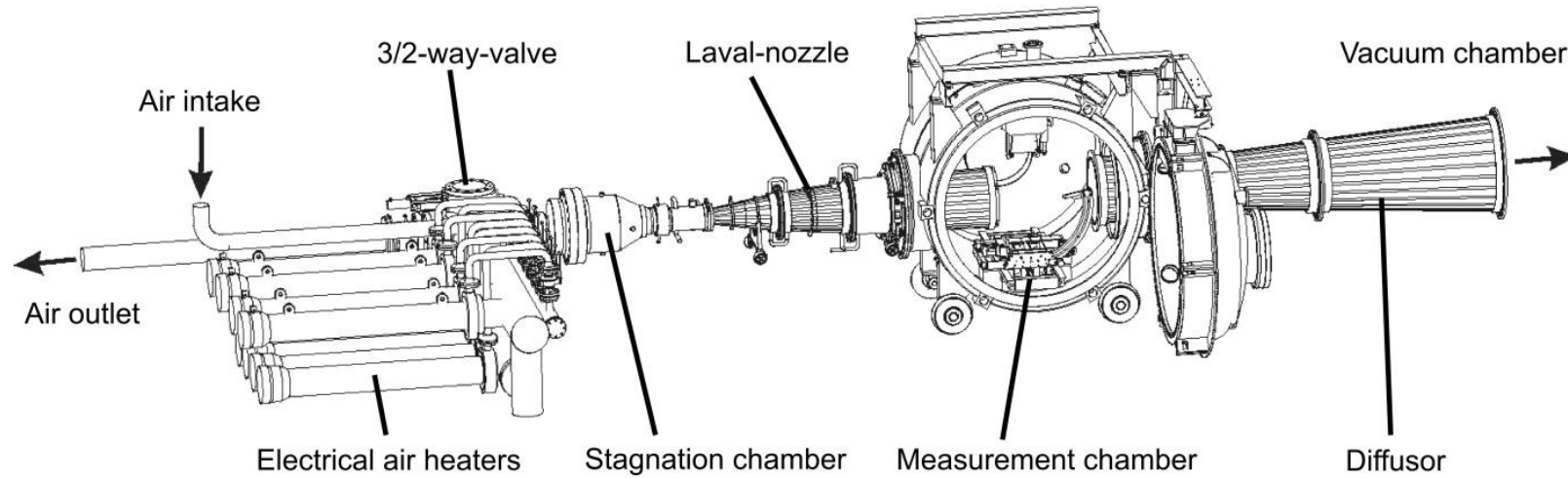

Name	Ma [-]	p_0 [bar]	T_0 [K]	Re_u [1/m]	Re_ϕ [-]	AoA [°]	Φ [Hz]
TC1	7.1	24.0	600	9.9e6	0.99e6	0°	0, ±0.8, 4, 8
TC1	7.1	24.0	600	9.9e6	0.99e6	-10°	0, ±0.8, 4
TC1	7.1	24.0	600	9.9e6	0.99e6	-15°	0, 0.8, 4
TC2	7.0	4.8	600	2.1e6	0.21e6	0°	0, 0.8
TC2	7.0	4.8	600	2.1e6	0.21e6	-10°	0, 0.8



Set-up in H2K

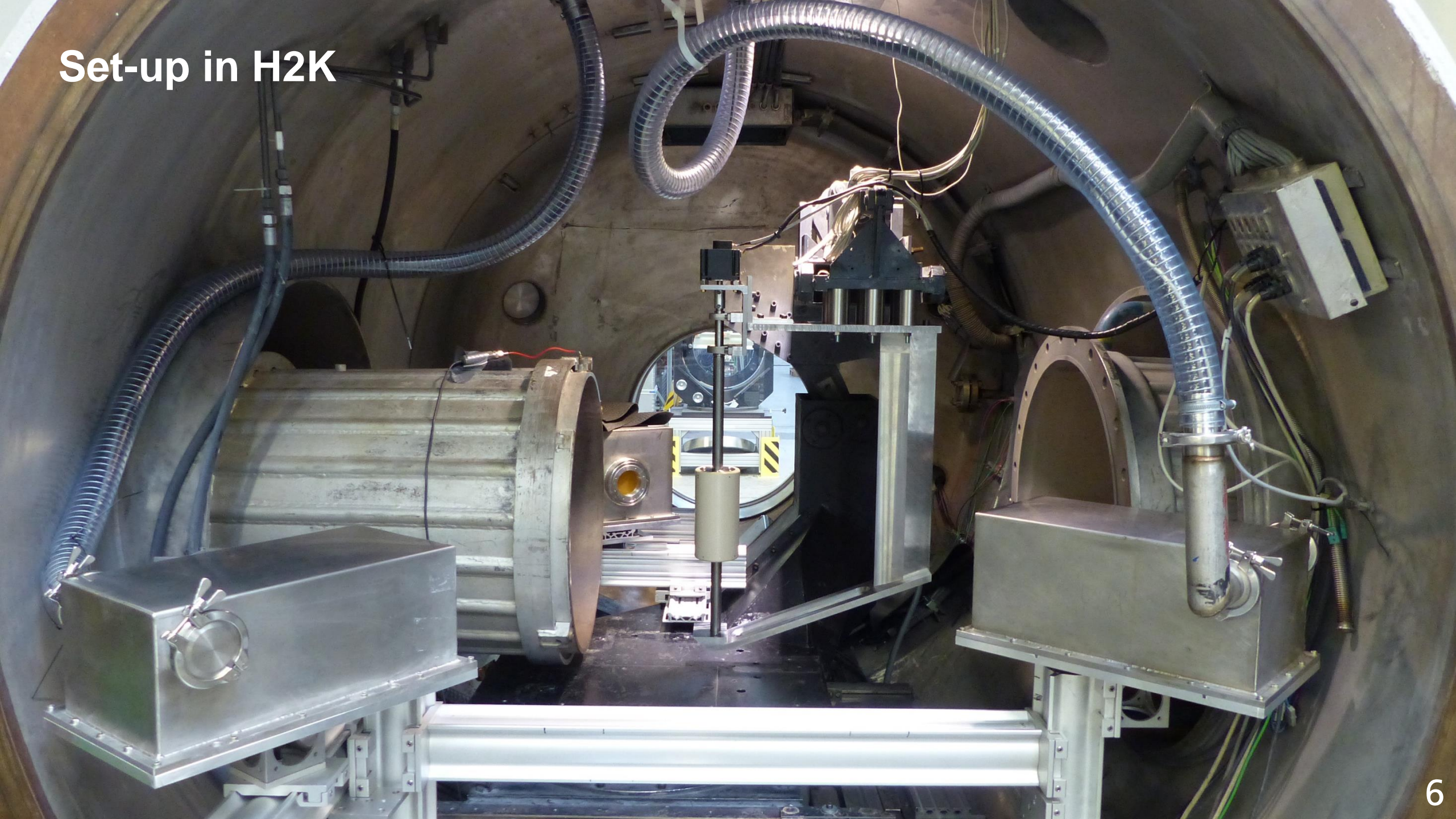

Set-up in H2K



Set-up – IR cameras

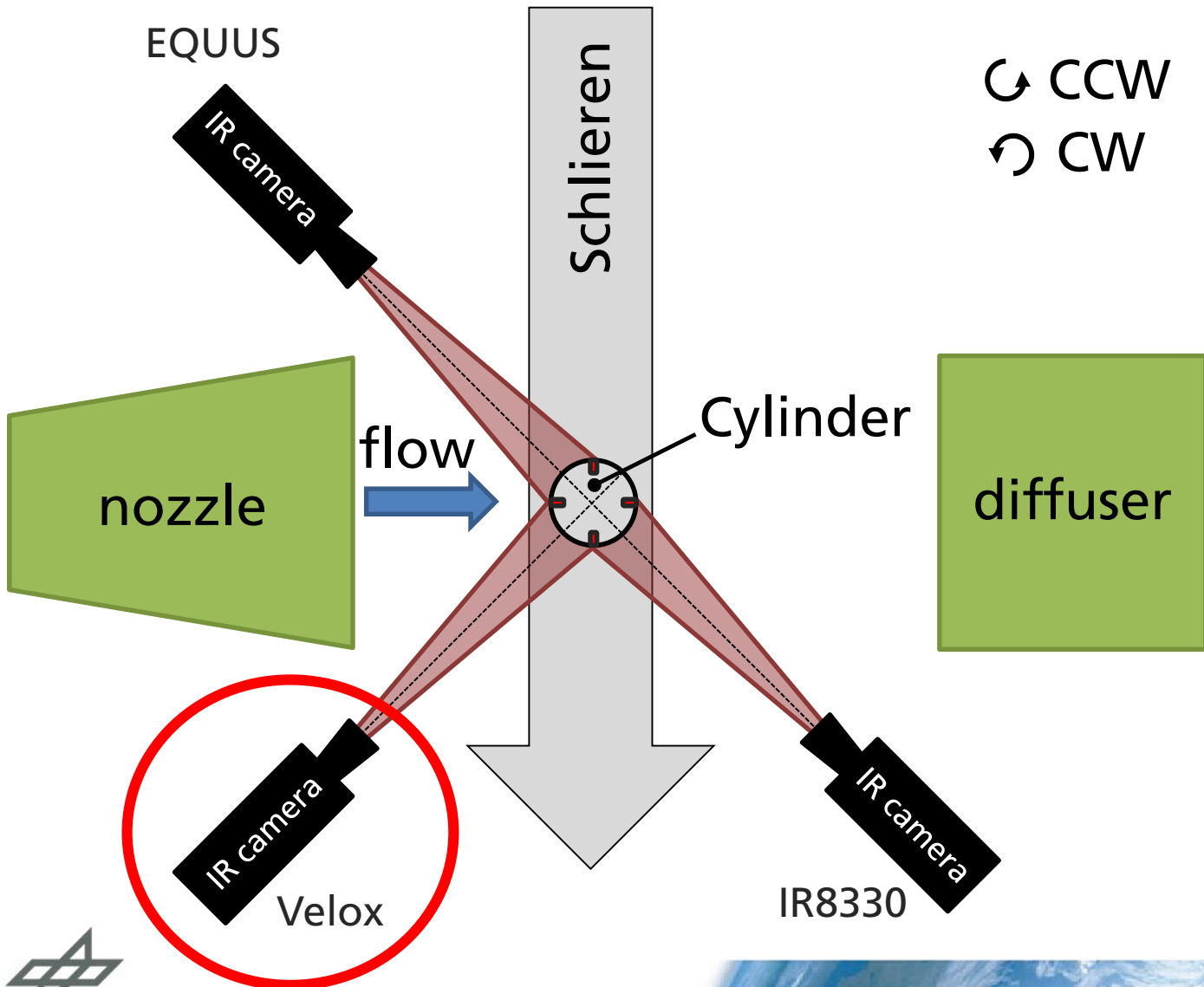

- IRCAM Velox 1310k SM
 - 1280 x 1024 pixel
 - 1.5 – 5.5 μm
- IRCAM EQUUS 327k L
 - 640 x 512 pixel
 - 7.7 – 9.4 μm
- InfraTec IR8330
 - 640 x 512 pixel
 - 2.0 – 5.0 μm

Set-up – Schlieren cameras

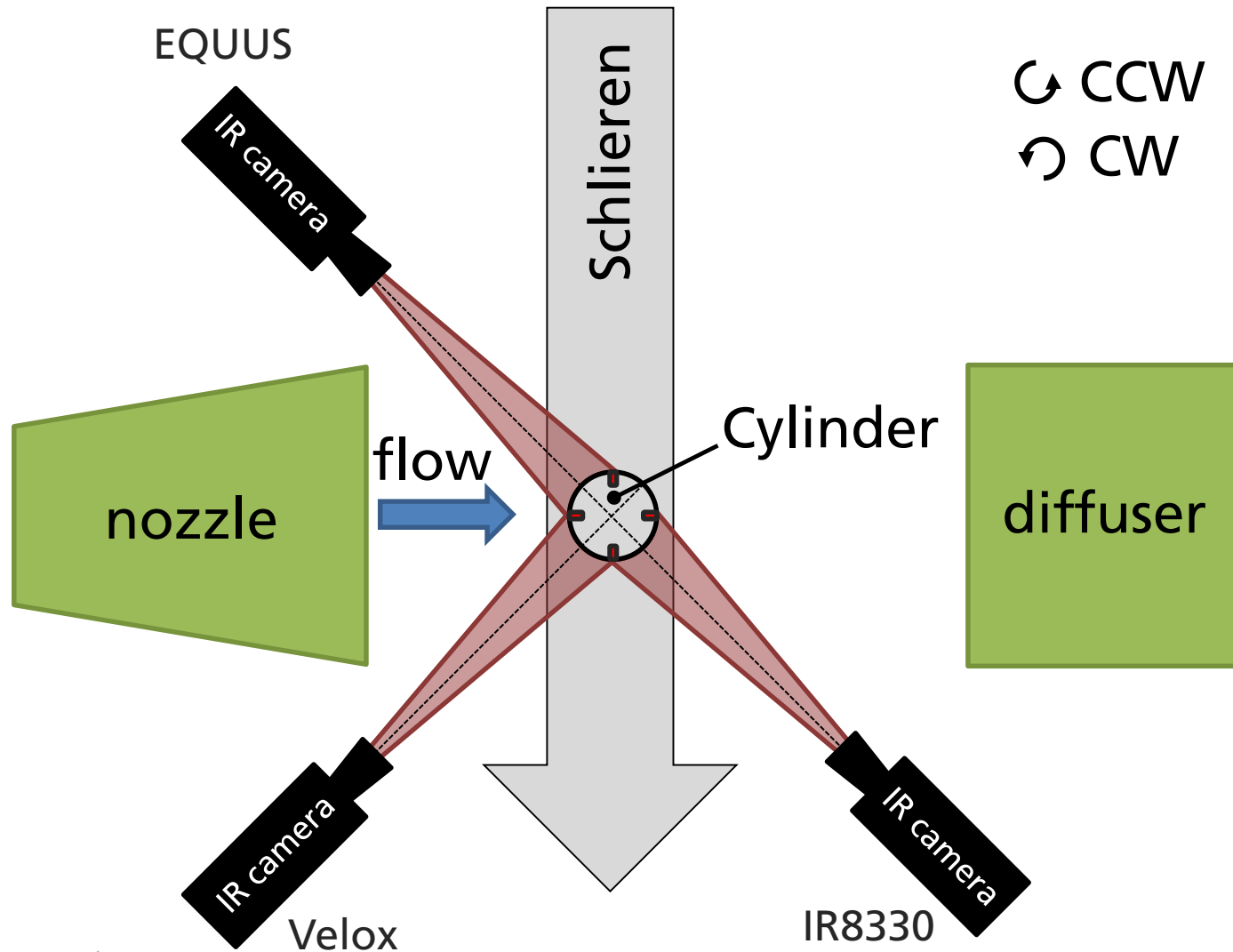

- Photron FASTCAM SA-X2
 - 1024 x 1024 pixel
 - 12.5 kHz
- Nikon Z6
 - 1920 x 1080 pixel
 - 120 Hz



Set-up in H2K

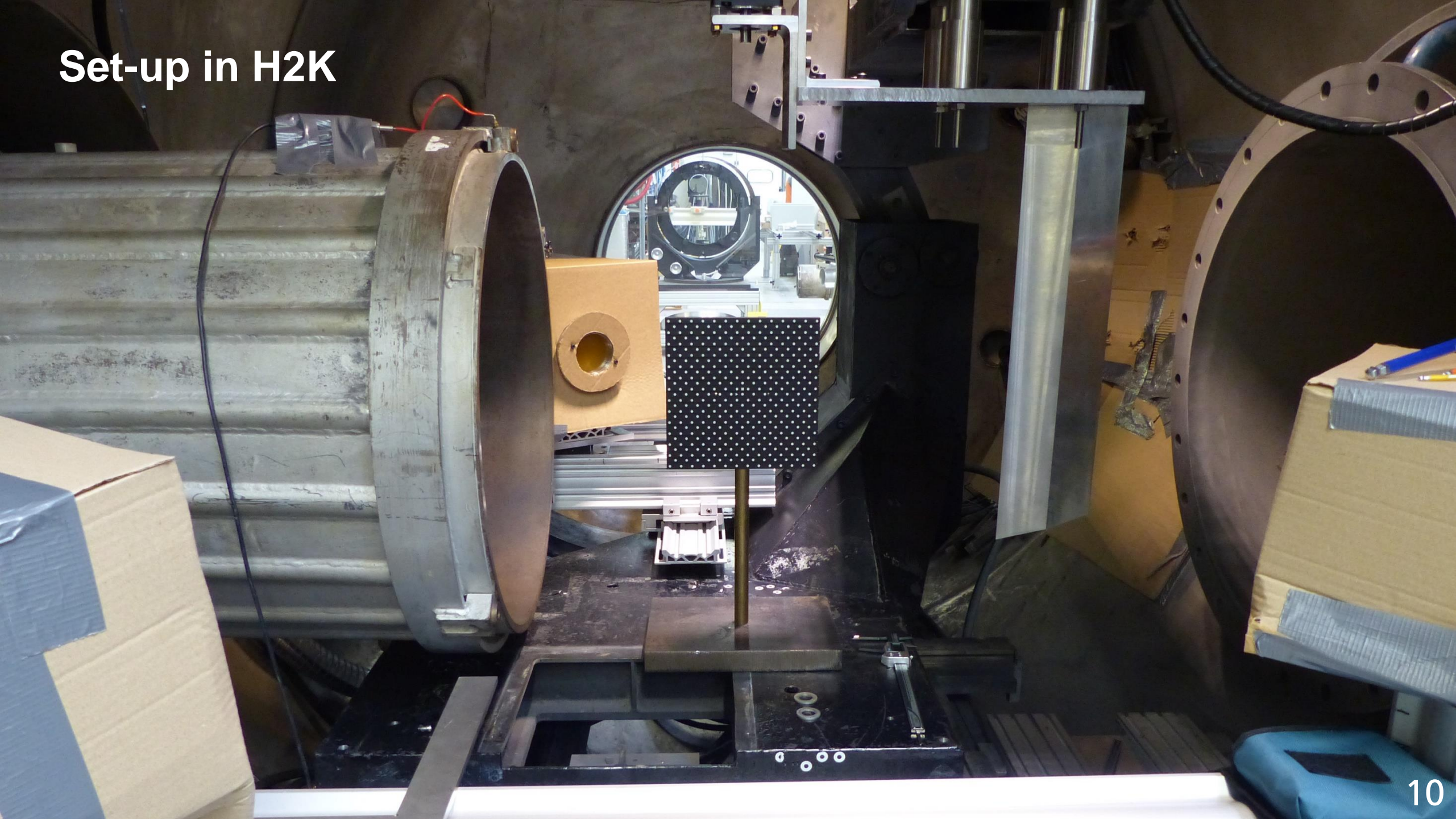

Schlieren image

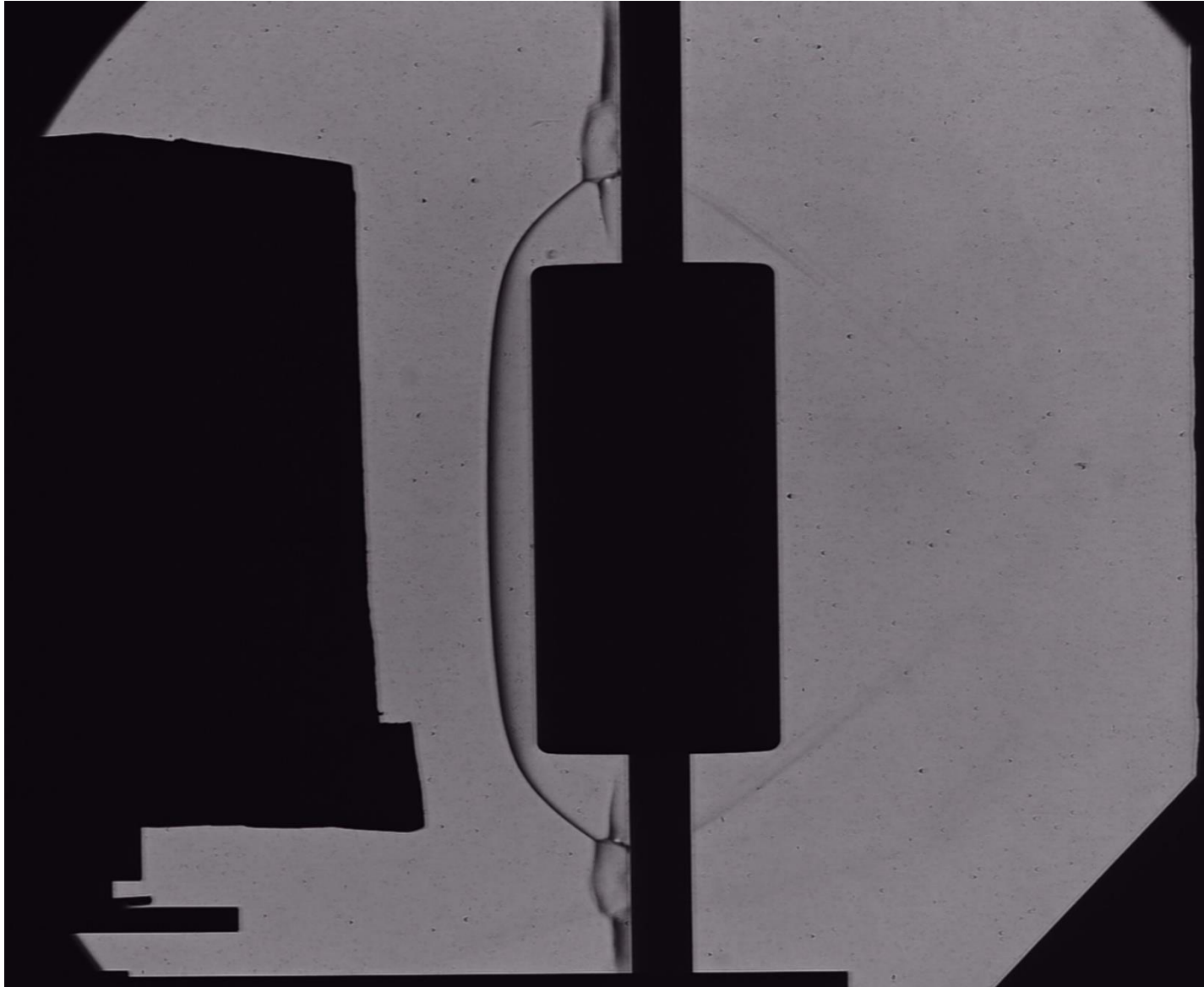

Influence of test condition

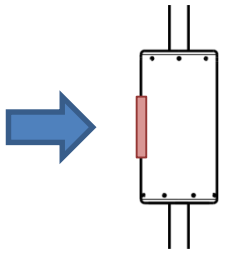
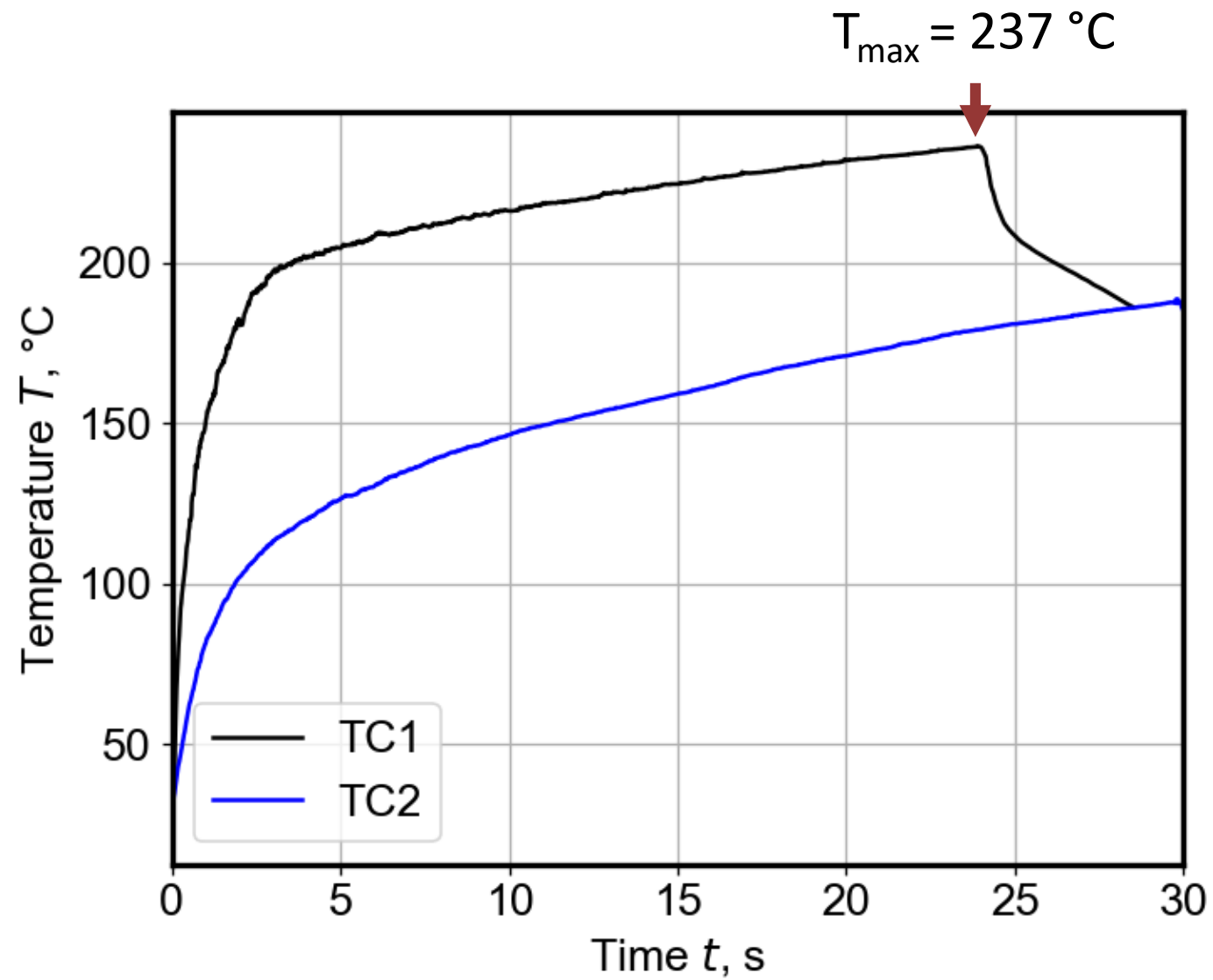

Influence of test condition

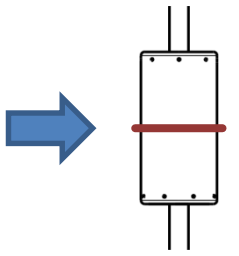
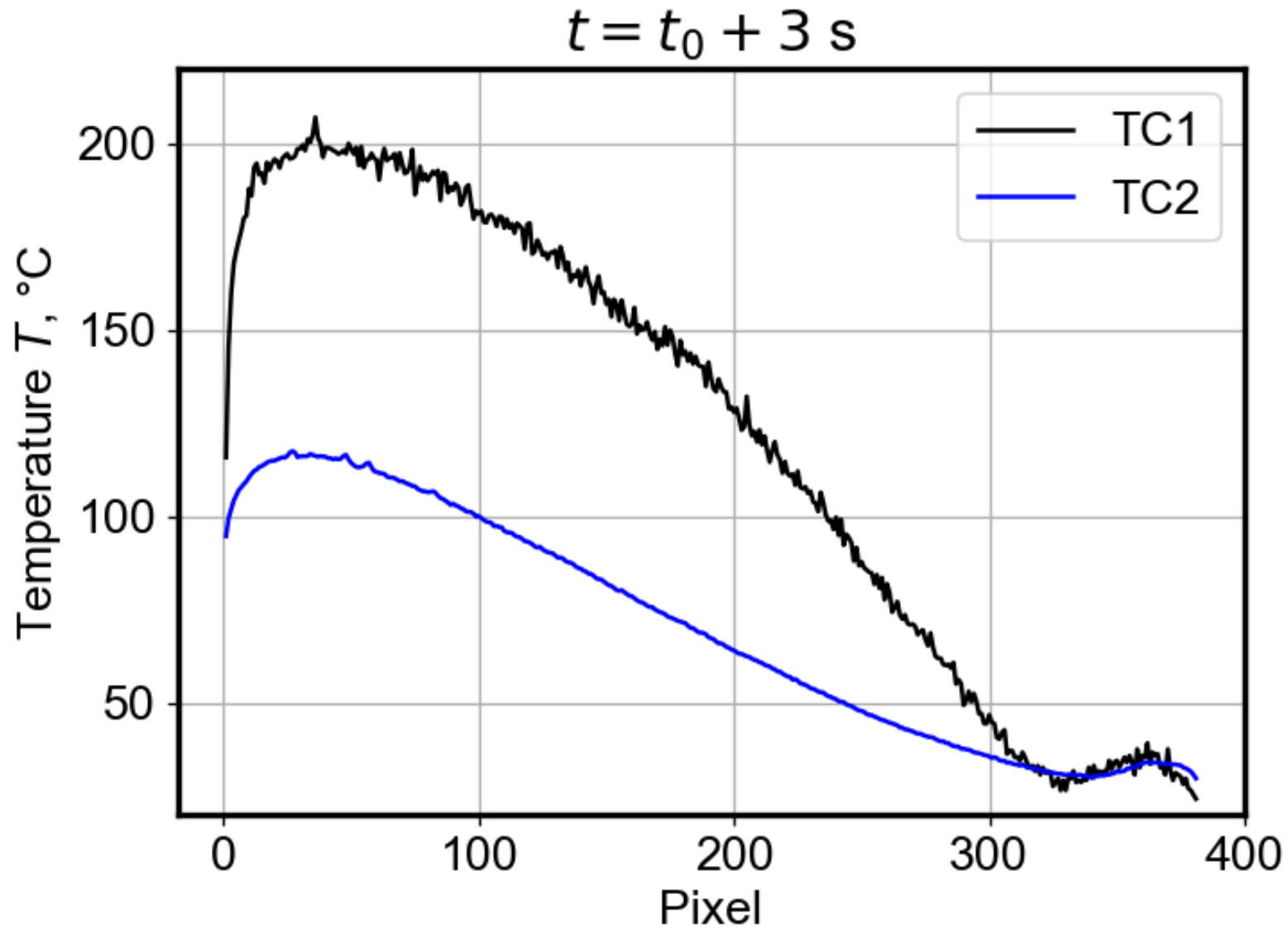

Influence of rotation speed

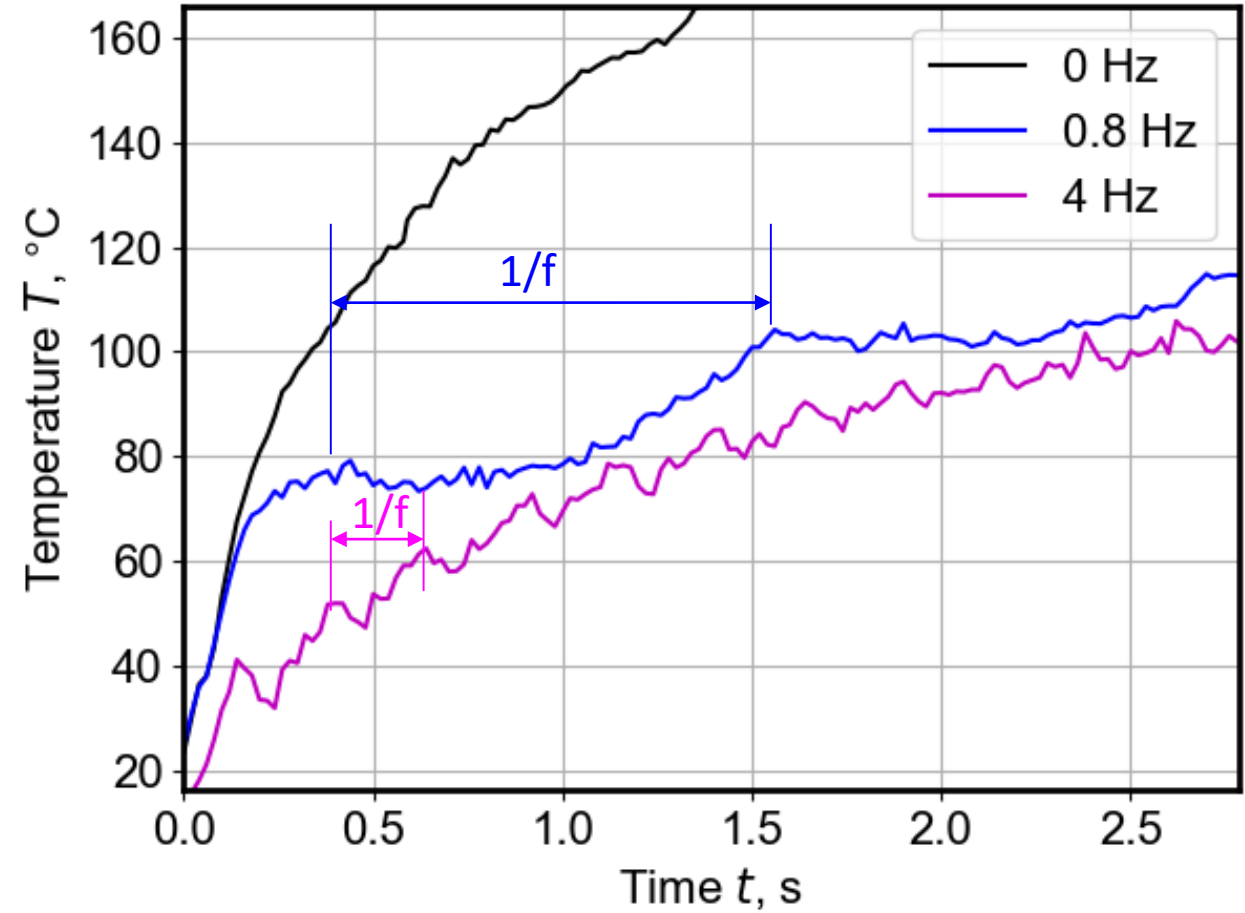
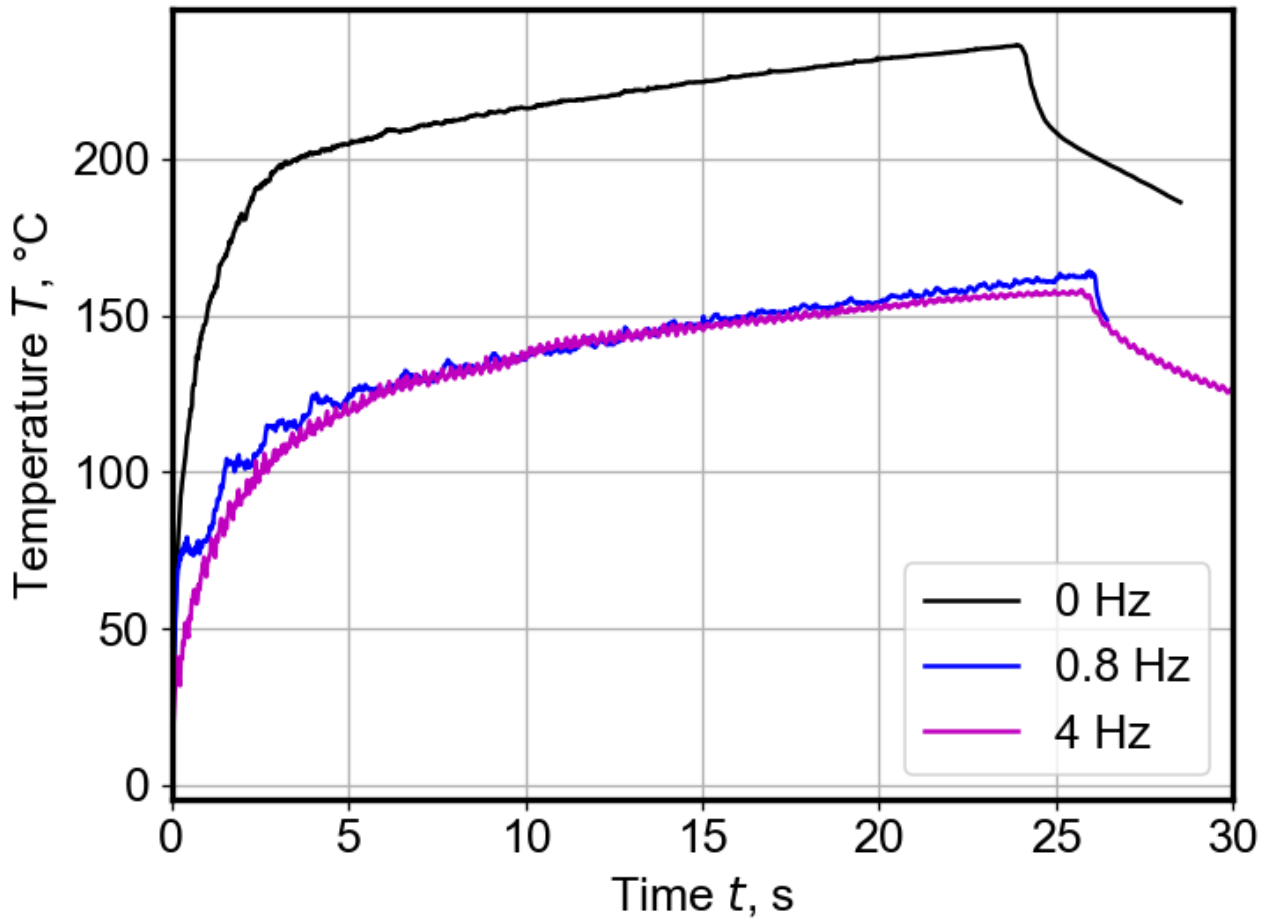
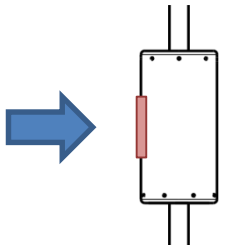

Influence of rotation speed

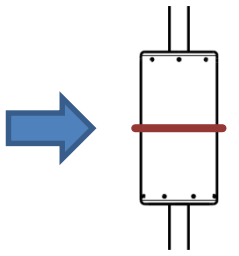
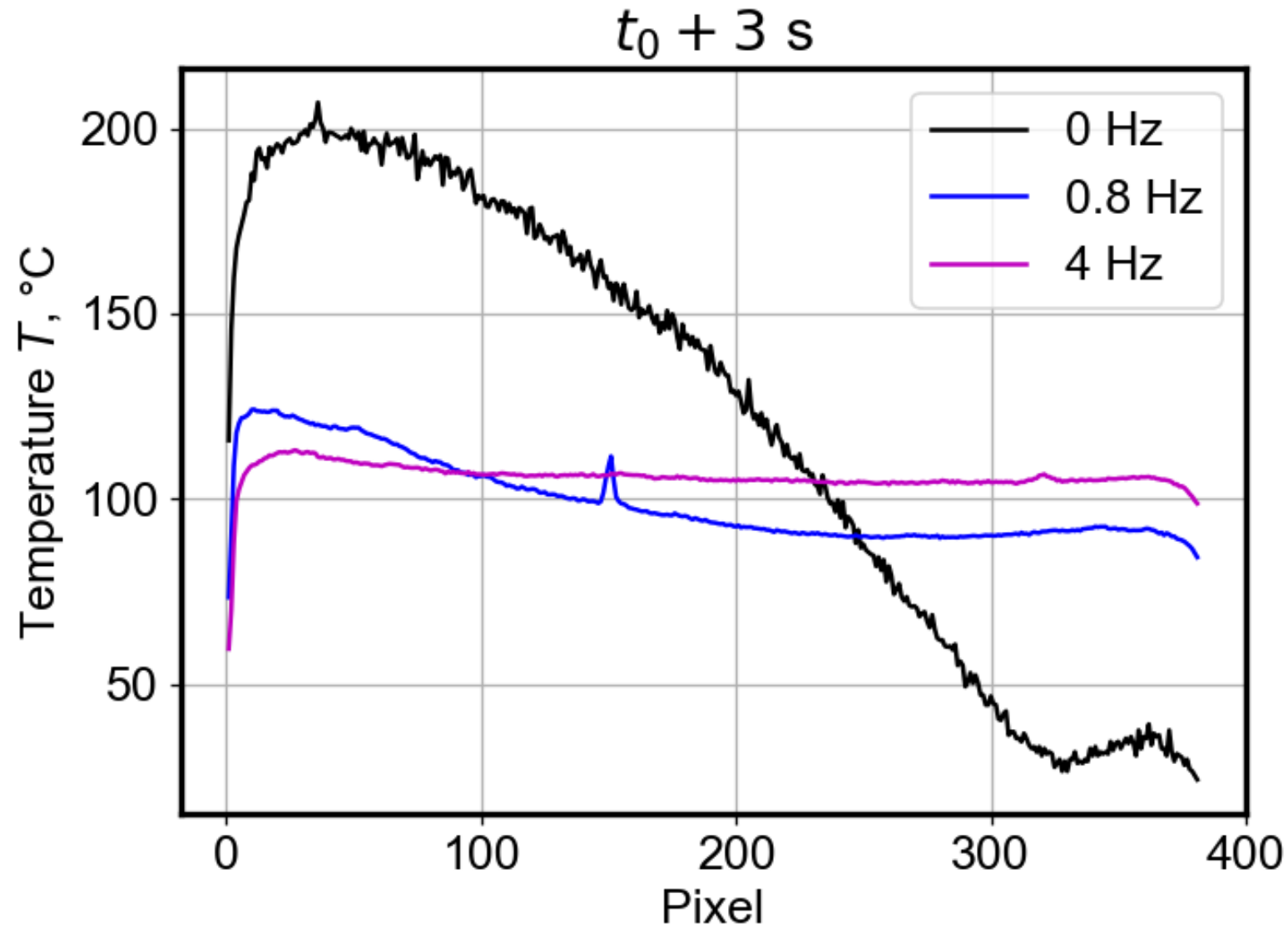

Influence of rotation speed

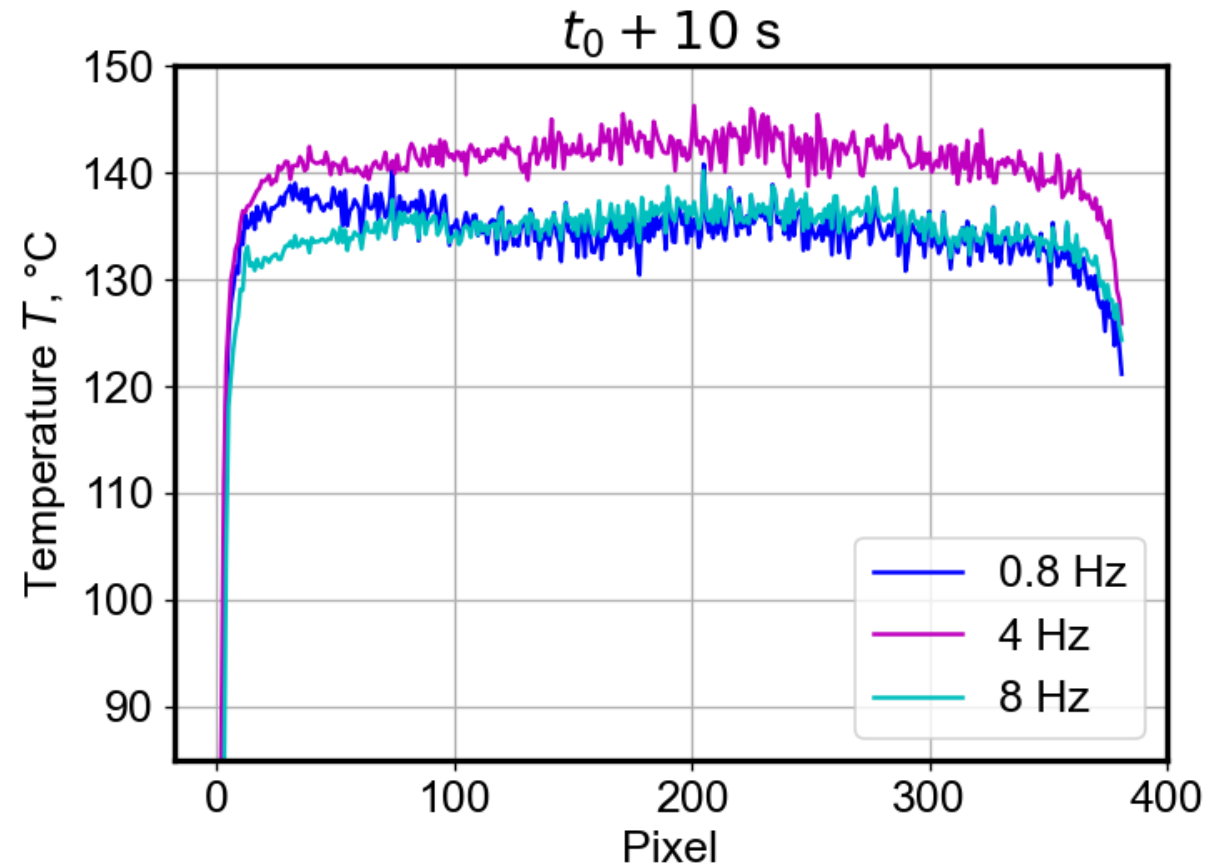
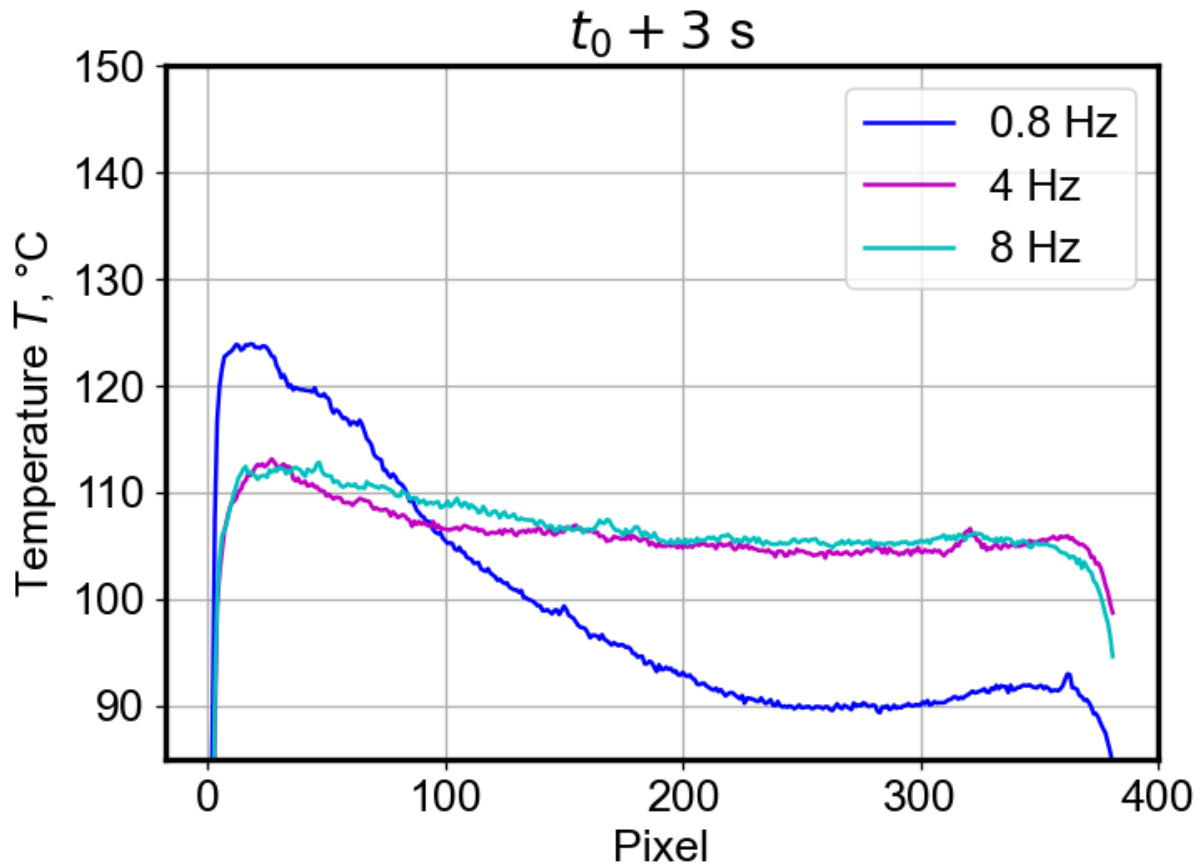
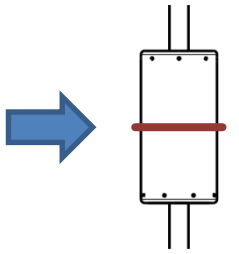

Influence of rotation direction

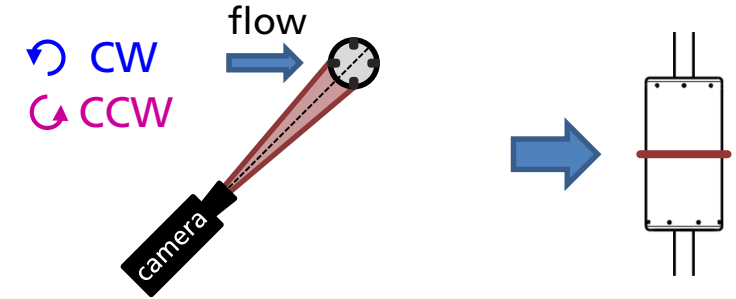

$f = 0.8 \text{ Hz}; t_0 + 5 \text{ s (+ 4 rev.)}$

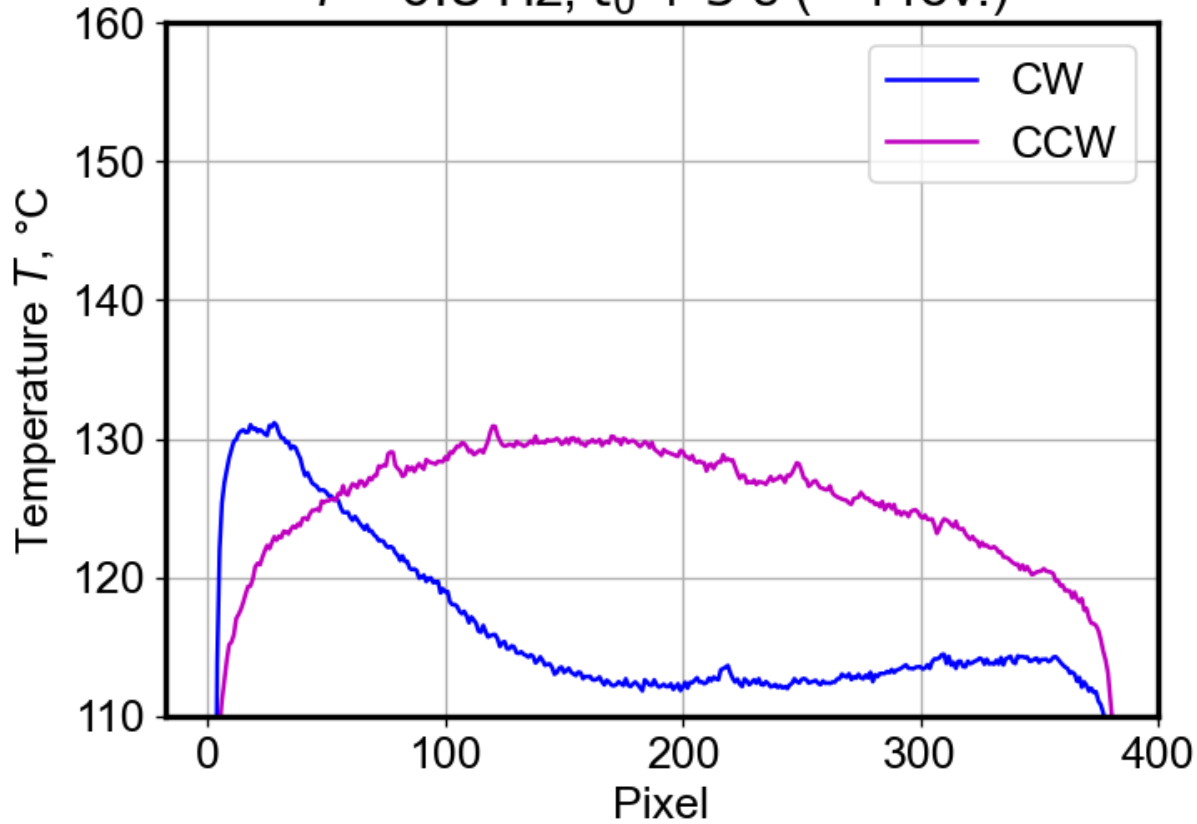

$f = 0.8 \text{ Hz}; t_0 + 10 \text{ s (+ 8 rev.)}$

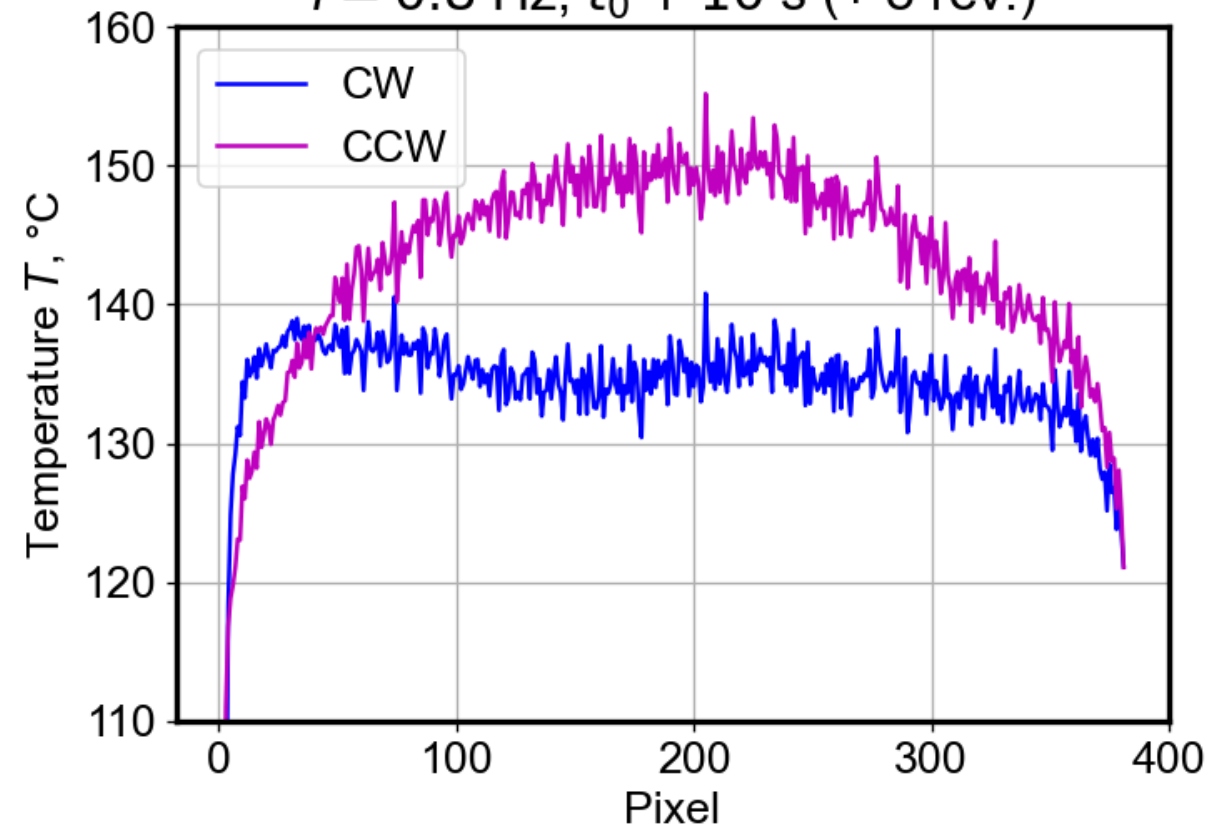

Repeatability

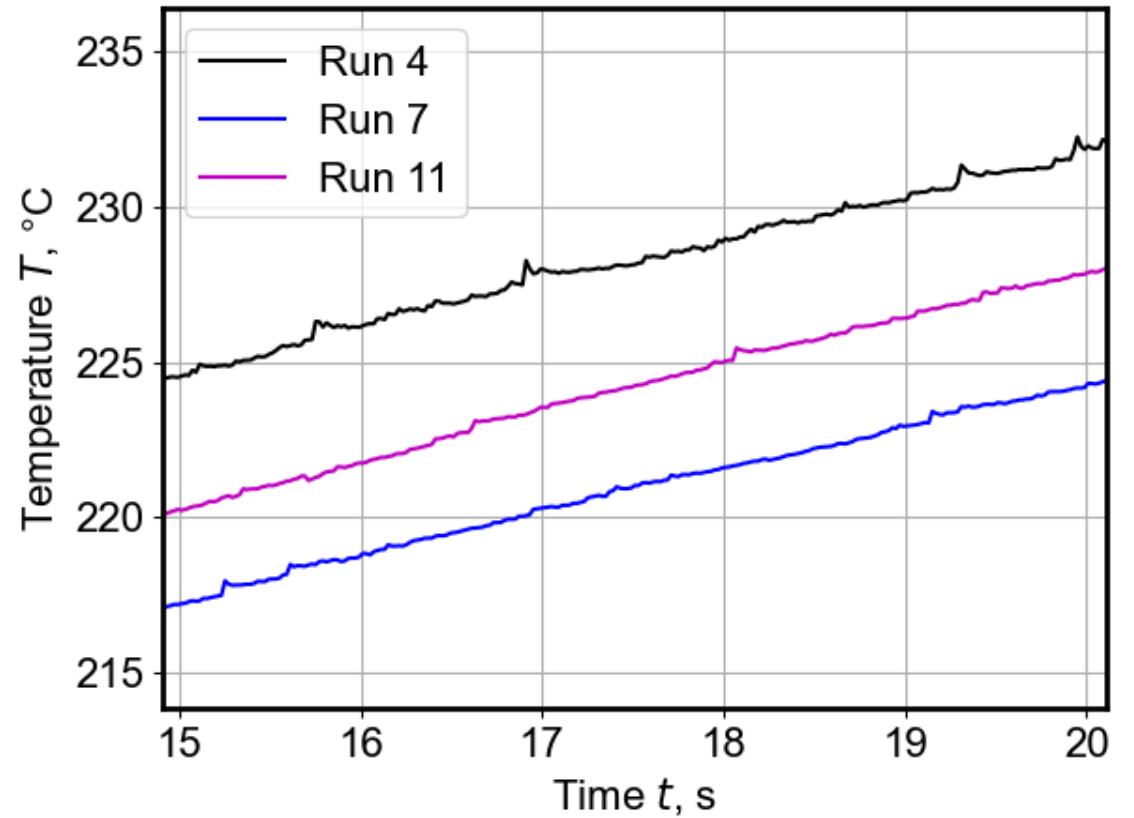
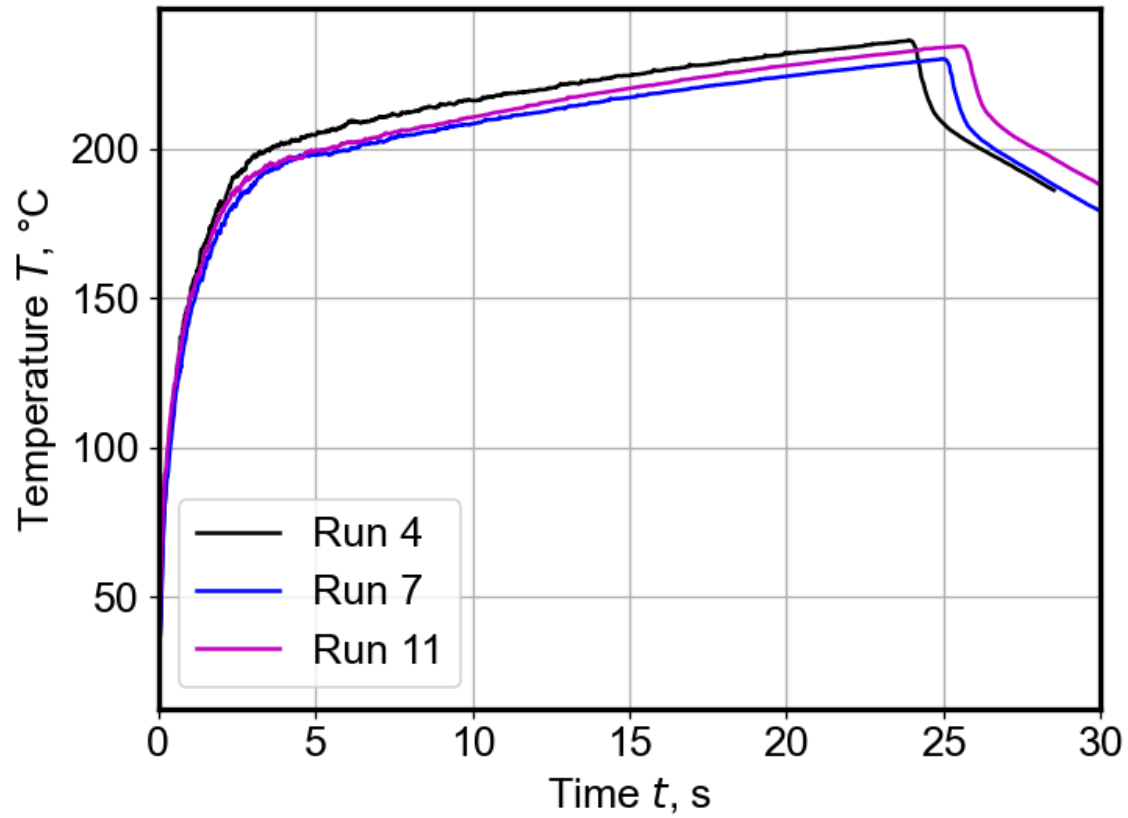
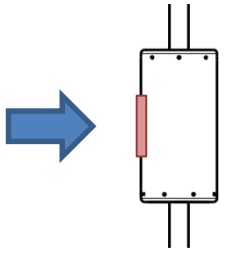

Repeatability

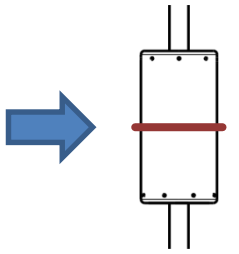

TC1; $t = t_0 + 3 \text{ s}$

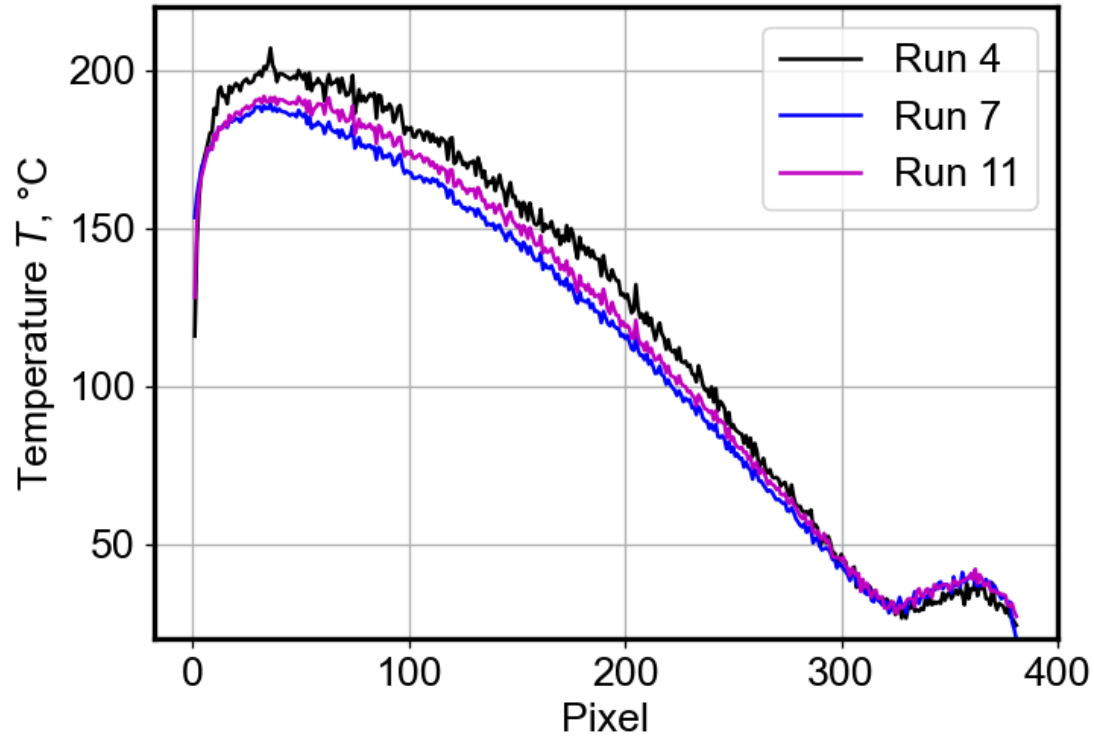

TC1; $t = t_0 + 3 \text{ s}$

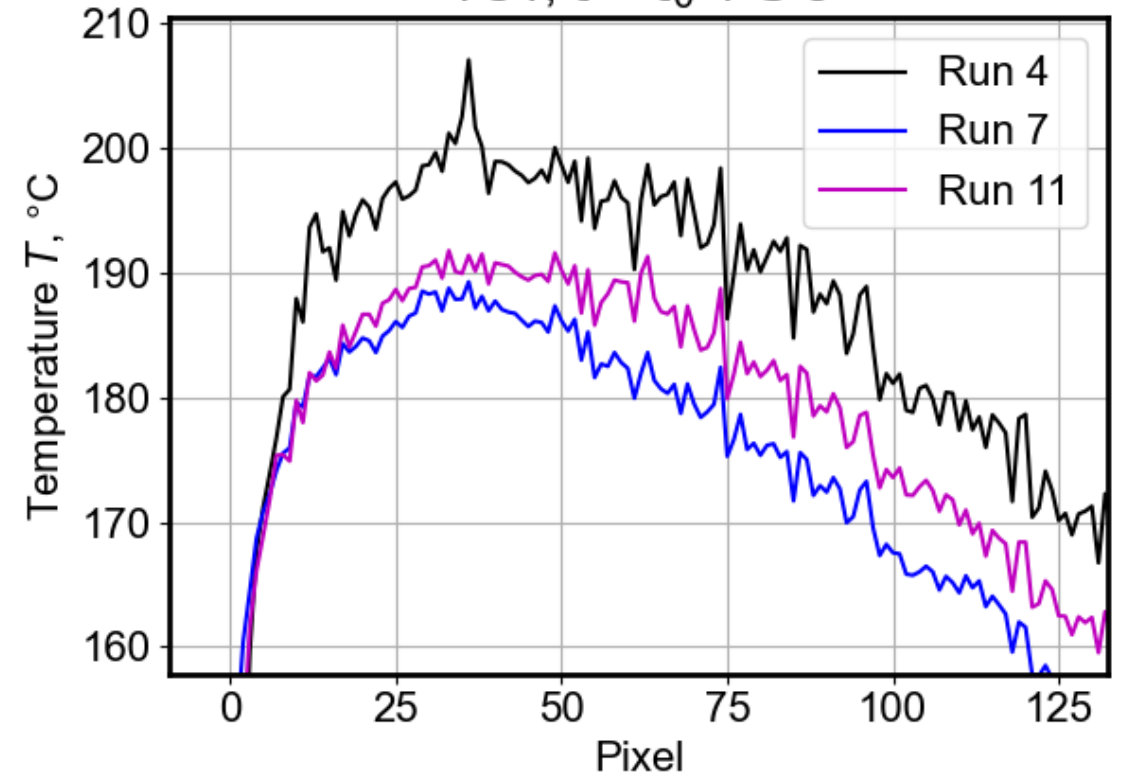

Striped pattern on cylinder

TC1
0.8 Hz
Run 10
 $Re = 9.9e6 m^{-1}$

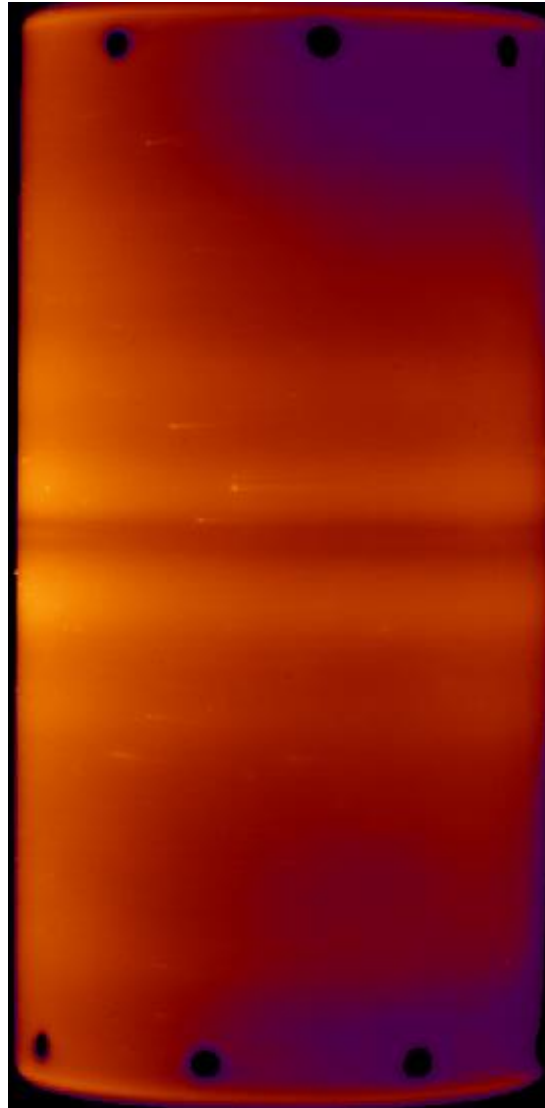

TC2
0.8 Hz
Run 14
 $Re = 2.6e6 m^{-1}$

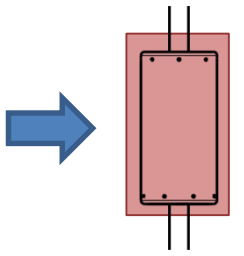
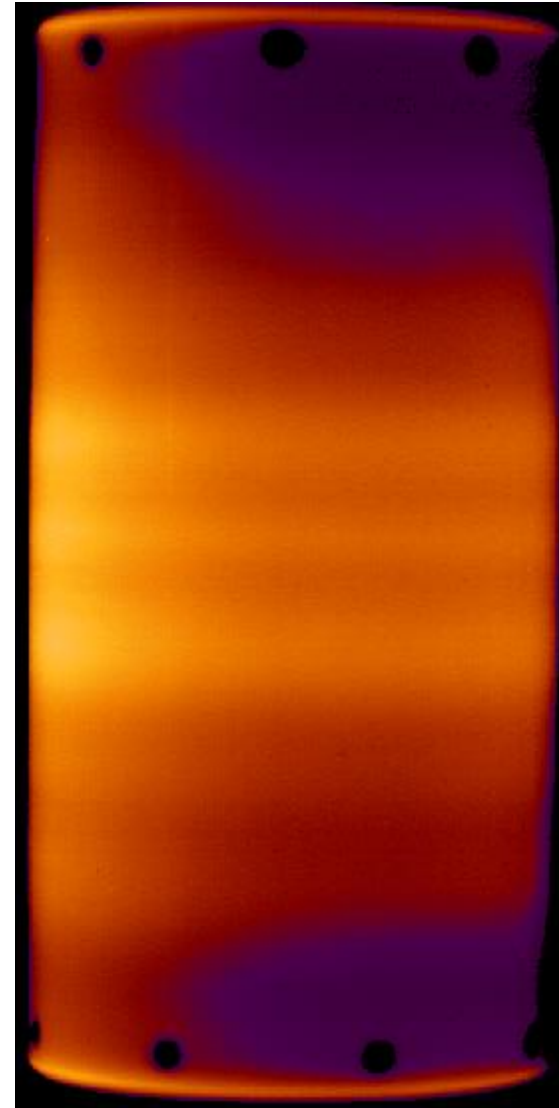

Striped pattern on cylinder

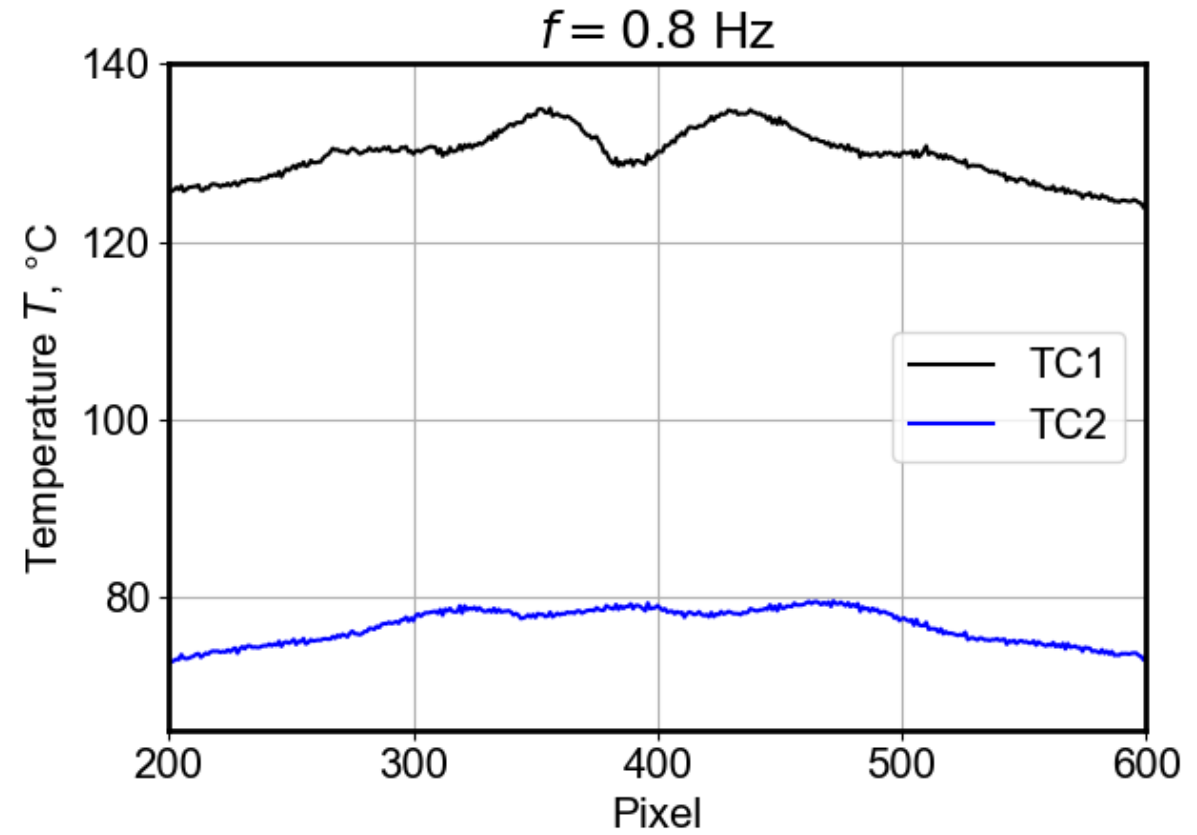
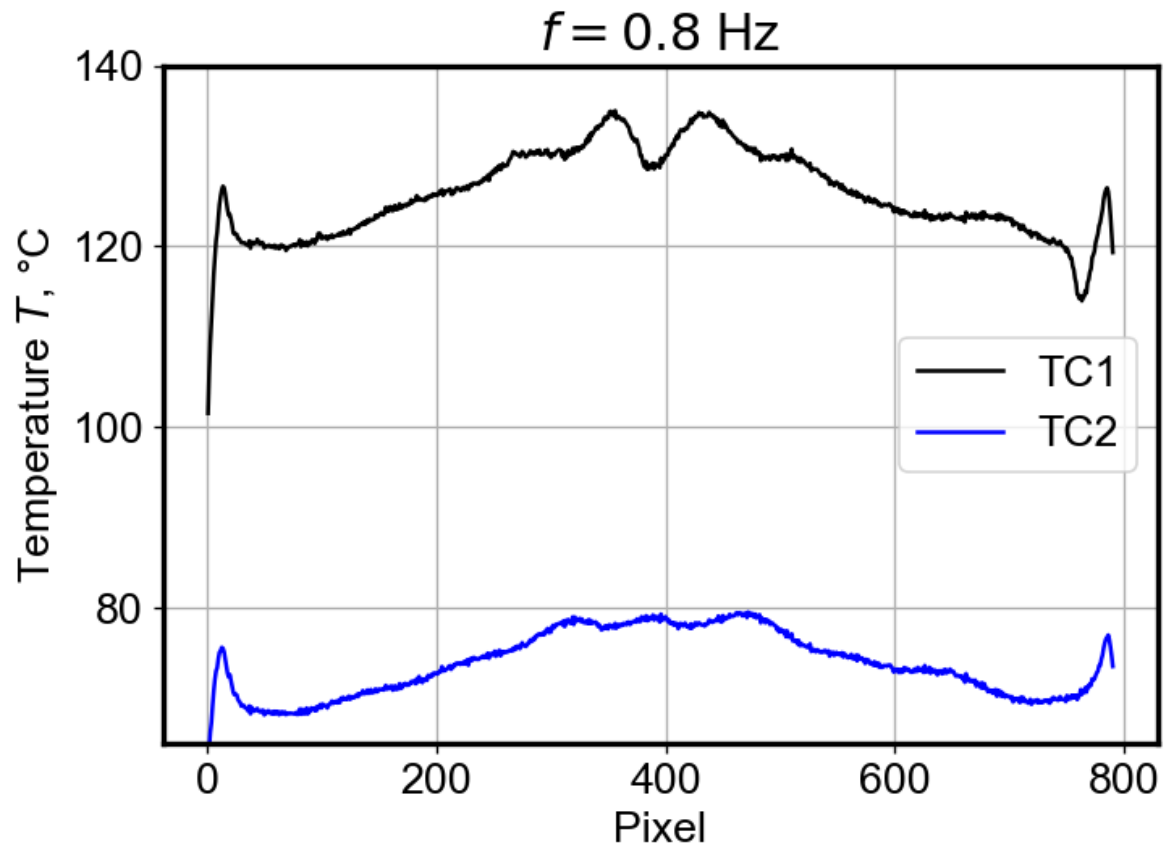
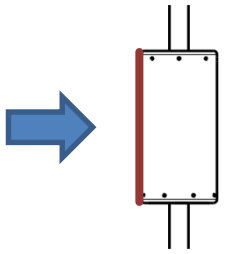

Striped pattern on cylinder

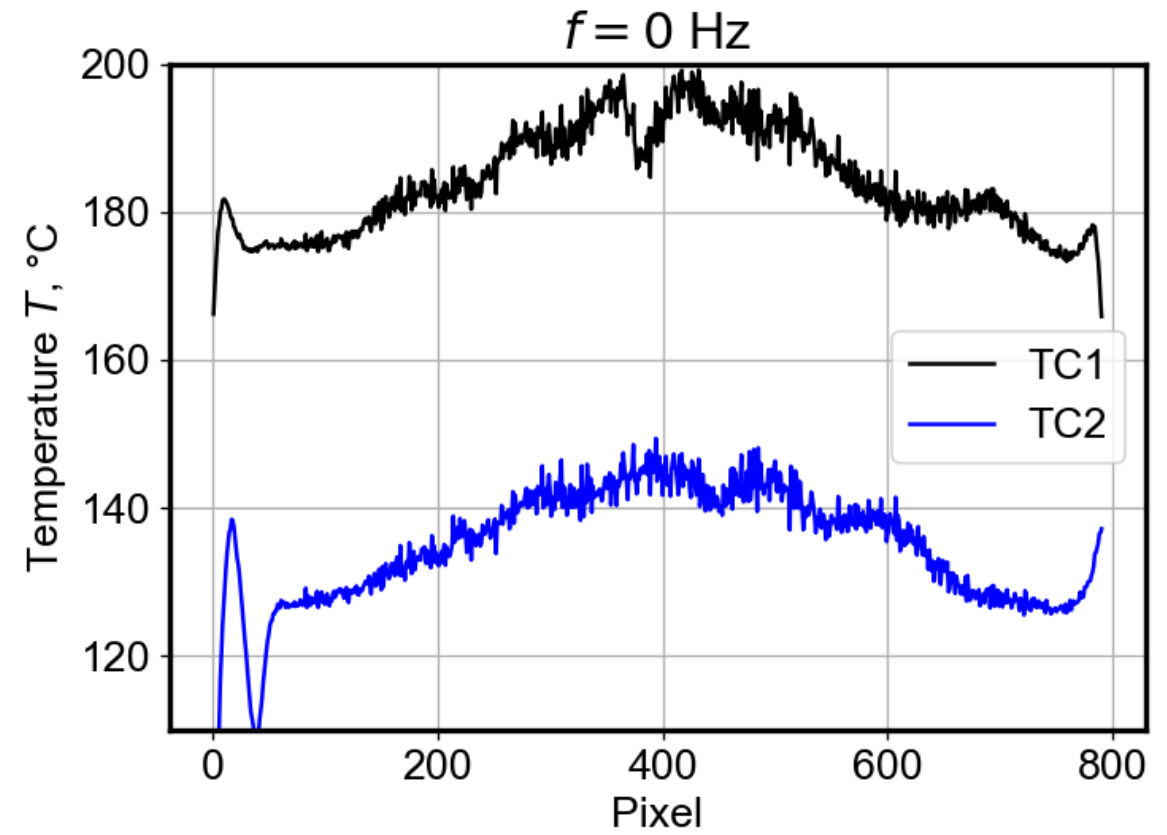
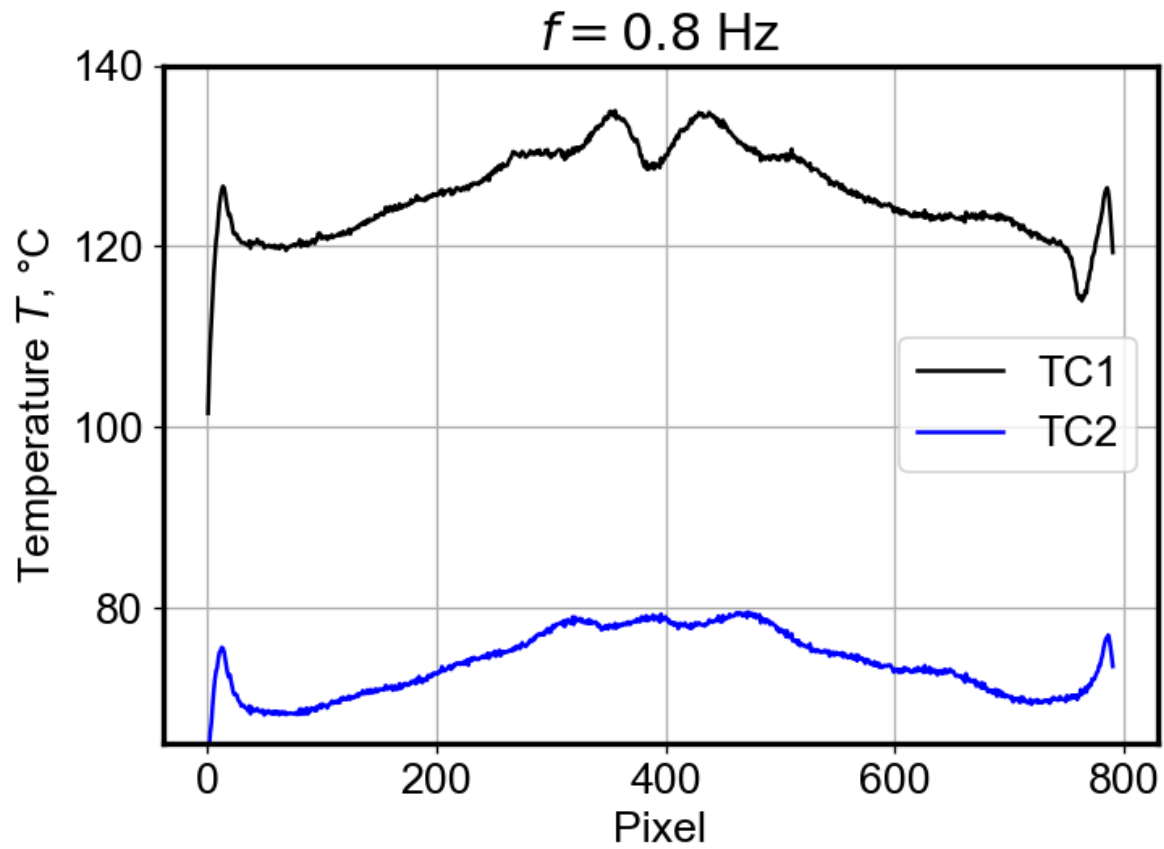
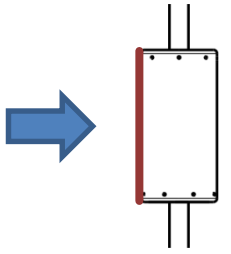

Striped pattern on cylinder

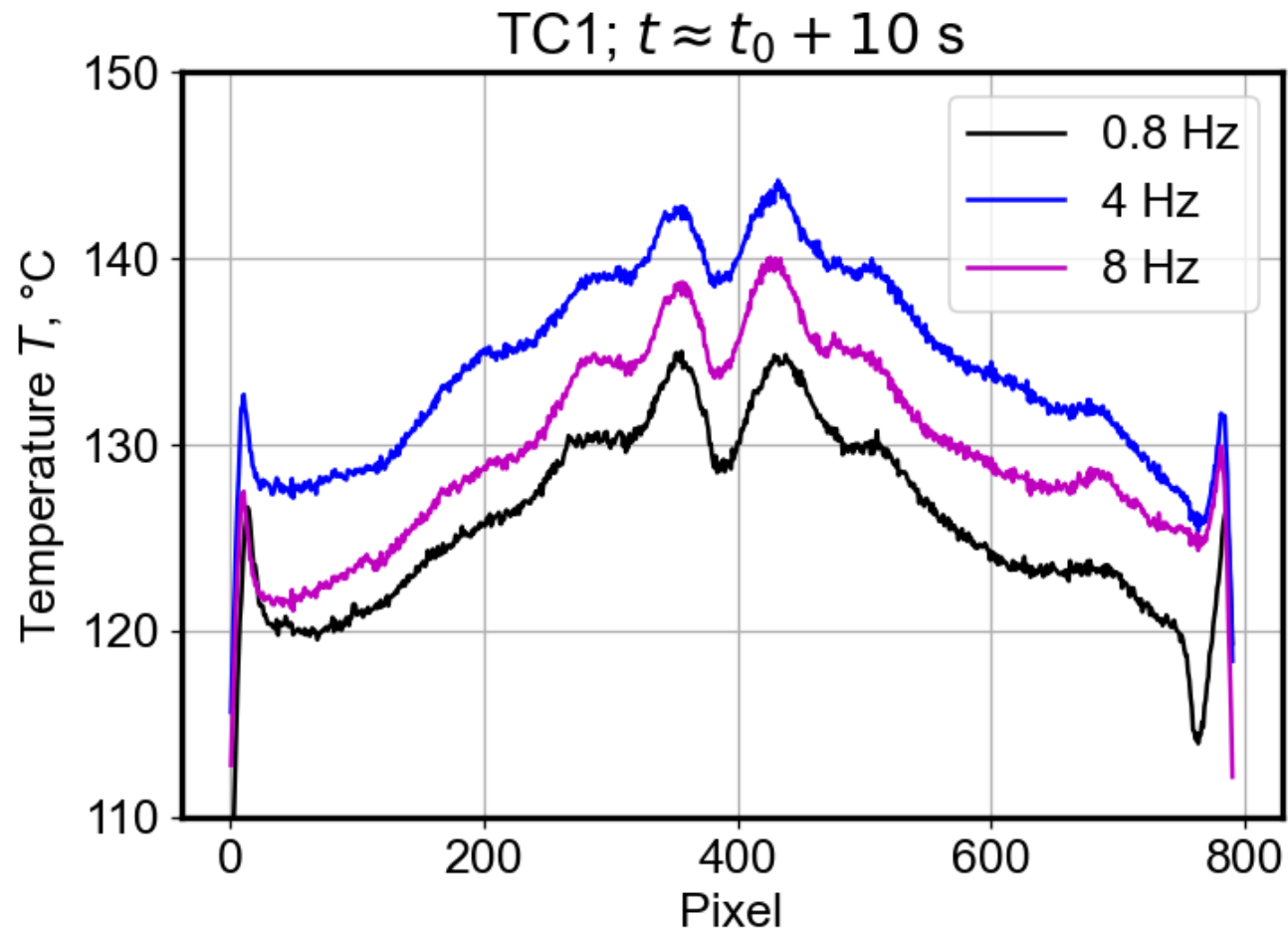
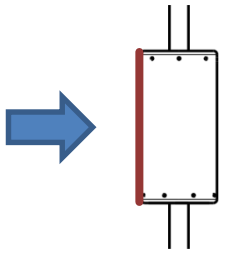

Conclusion

- Set-up works
- Challenging measurement with 3 IR cameras
- Pattern on cylinder (stripes, stagnation line, separation line, ...)
- Effect of rotation measurable

Outlook

- Post processing in progress (mapping, heat fluxes, Stanton number, ...)
- Different shapes
- Different rotation axis

