



# Mid-Size Satellites Industrialisation (M-IND)

## *Request for Information (RFI) - Webinar*

31<sup>st</sup> March & 10<sup>th</sup> April 2026

(last update on 28-April - 2026 - to include Q&A in the last 4 slides)

Available at [indico](#) and at [esastar](#) as [MIND-RFI-Webinar.pdf](#)

ESA UNCLASSIFIED - For ESA Official Use Only



→ THE EUROPEAN SPACE AGENCY

# M-IND – how did it start ?

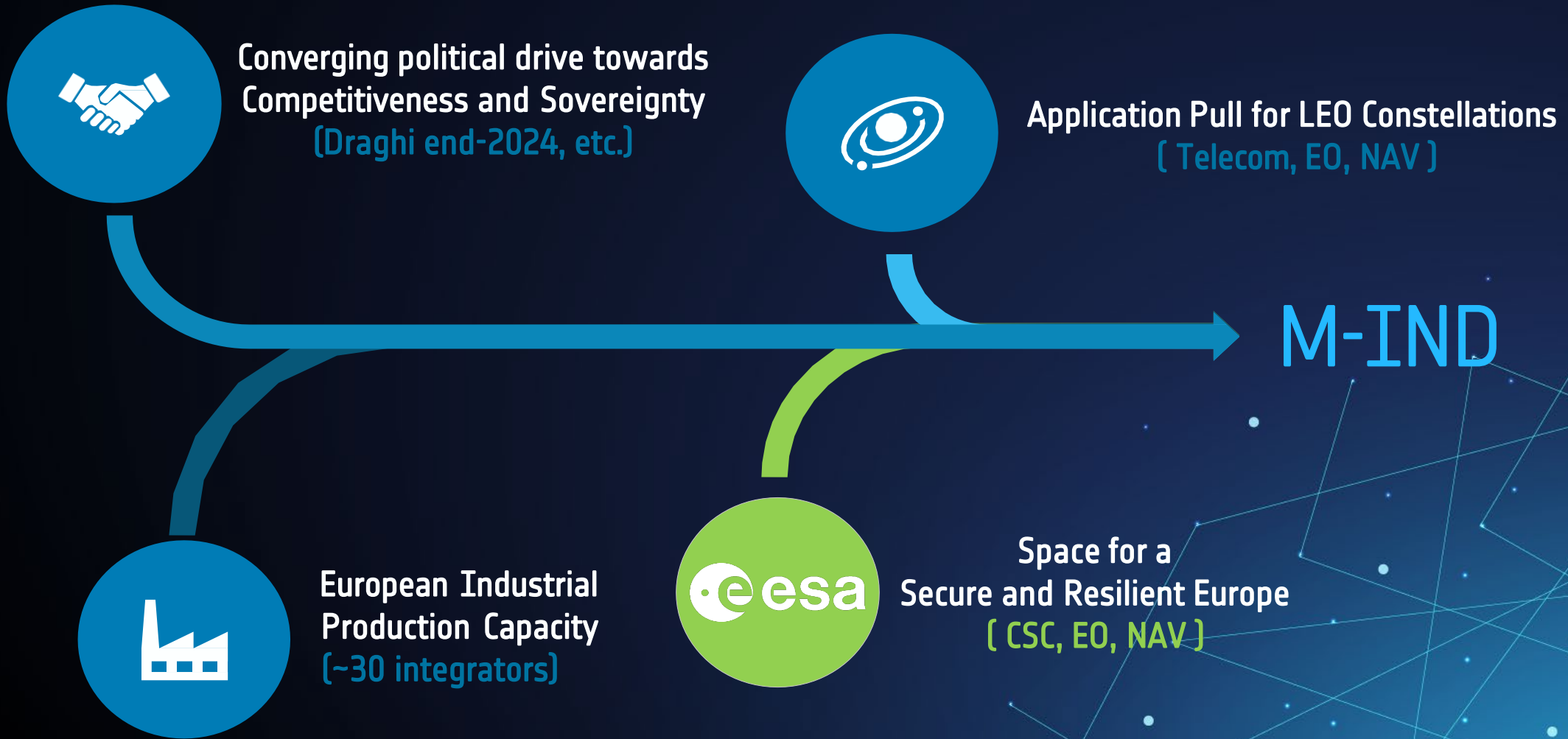

# M-IND: Mid-size sat INDustrialisation for LEO constellations

□ M-IND aims at increasing production **volume** & reducing **cost** and **lead-time**:

- **Interoperable** and **interchangeable** :
  - Platform equipment & modules
  - Payload modules
- **A robust and sovereign supply chain** addressing the increasing demand of European integrators
  - For ESA missions
  - National missions
  - Commercial prospects
- Scaling up existing solutions: **TRL 6-7** and **MRL 6-7** by 2028

**M-IND envelope**  
100 to 500+ kg  
200 to 3.6 kW

Payload

Application-specific platforms

- Can share common subsystems:
- Avionic (Data handling, on-board computer & flight SW)
  - Power (Solar Gens, batteries, distribution & harness)
  - AOCS
  - TT&C & PDT
  - Propulsion
  - Mechanical and Thermal

M-IND envelope:  
100 to 500+ kg; 200 to 3.6 kW

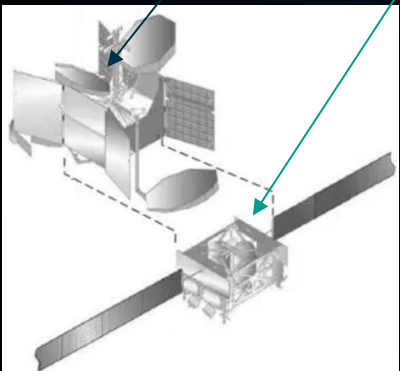

March-2025: 30+ integrators consulted



March-2026 (interfases): 20 integrators + 35 Suppliers consulted (Hybrid Workshop)

# M-IND: Industry-driven recommendations

- 35+ integrators involved in the M-IND initiative
- Survey on platform subsystems pain-points (Feb-25)
- Workshop at ESTEC 20<sup>th</sup> March 2025



## 5 major M-IND recommendations

*[see M-IND Report, sent to IPC TAWG delegates in June-2025]*

1. Industrialisation (MRL; support transition highly customised low volume to serial production)
2. Industrial Policy
3. Reduction and communalisation of interfaces - Workshop on 10-03-2026
4. Platform Equipment & Modules + Payload modules □ Sovereign supply chain + interchangeability
5. Constellation deployment and operations

*M-IND Request for Information (RFI) - early March 2026*

# M-IND RFI in OSIP

RFI Webinar Q&A on 10<sup>th</sup> April @ [indico.esa.int](https://indico.esa.int)

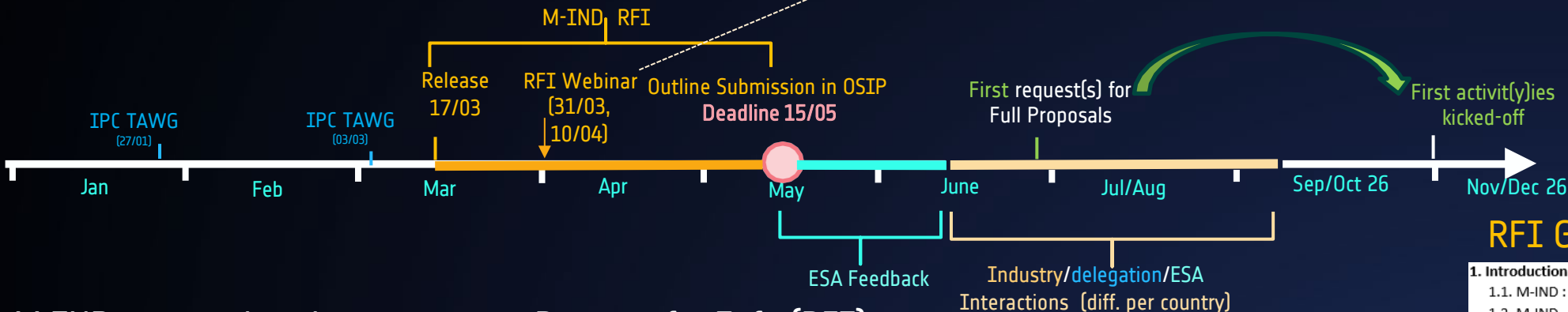

M-IND proposals – in response to Request for Info (RFI):

- using the standard **GSTP Building Block outline template** ([link](#))
- and the **M-IND Checklist**

INDustrialisation / Serialisation Support Campaign

Submit Your Idea

considering (full) phased-approach – **example** □ 2028 target

Phase Nb	Title	TRL		MRL		Months	Budget (k€)	
		Start	Target	Start	Target		ESA price	Full cost
1	Consolidation - Feasibility	4+				4	<b>GSTP</b>	<b>Elem.1</b>
2	Finalise Product		6 / 7			12	<b>TBD</b>	
3	Industrialisation			7		10	<b>Option</b>	<b>al Prog.</b>

## RFI Guidelines ([esastar](#))

1. Introduction to M-IND and this M-IND RFI.....
  - 1.1. M-IND : Mid-size LEO satellite INDUSTRIALISATION.....
  - 1.2. M-IND – RFI (not contractually binding).....
  - 1.3. Phased-approach Roadmap in the M-IND RFI Outline Proposals.....
  - 1.4. Scope of the M-IND RFI.....
  - 1.5. For whom is this RFI?.....
  - 1.6. Priorities for M-IND activities – affecting the feedback.....
  - 1.7. Eligibility and feedback.....
  - 1.8. Timeliness - 2028.....
  - 1.9. Document breakdown.....
2. Applicable and Reference documents.....
  - 2.1. Applicable Documents.....
  - 2.2. Reference Documents.....
  - 2.3. Acronyms.....
3. Checklist for the M-IND RFI.....
  - 3.1. Paragraph 1 - Technical and Application part of [AD-1] : .....
  - 3.2. Paragraph 2 - Management Part:.....
  - 3.3. Paragraph 3 - Financial Part:.....
4. Preferred Equipment & Modules for Mid-size sats for LEO constellations.....
  - 4.1. Platform Sub-systems.....
  - 4.2. Payload Modules s for mid-size LEO satellites.....
5. High Level System Requirements / Boundaries.....
  - 5.1. System Level Requirements / Boundaries.....
  - 5.2. Equipment / Module Level Requirements.....
  - 5.3. Payload Modules requirements.....
  - 5.4. Common Interfaces and High Level Reference Architecture.....
  - 5.5. Sovereignty.....
  - 5.6. Sustainability Requirements for ESA missions.....
  - 5.7. Industrialisation Requirements.....
  - 5.8. Prevent Duplications.....
  - 5.9. Product Deliverables by the end of the Phase-1 Consolidation.....
6. Conclusion.....



# M-IND across ESA Programmes



Priority equipment/modules  
(Ph.1 funded by GSTP)

Mid-size  
LEO Sats



Satcom  
LEO Platform Products  
(e.g. IRIS<sup>2</sup>)

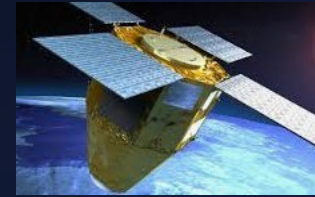

Earth Observ.  
LEO Platform Products  
(e.g. ERS-EO)



NAV  
LEO Platform Products  
(e.g. CELESTE)

Not all  
cross points  
apply to all

**Data Handling**

**Security**

**AOCS**

**Power**

**Comms / TT&C**

**Optical & RF Techno. Equip. & Modules**

**Propulsion**

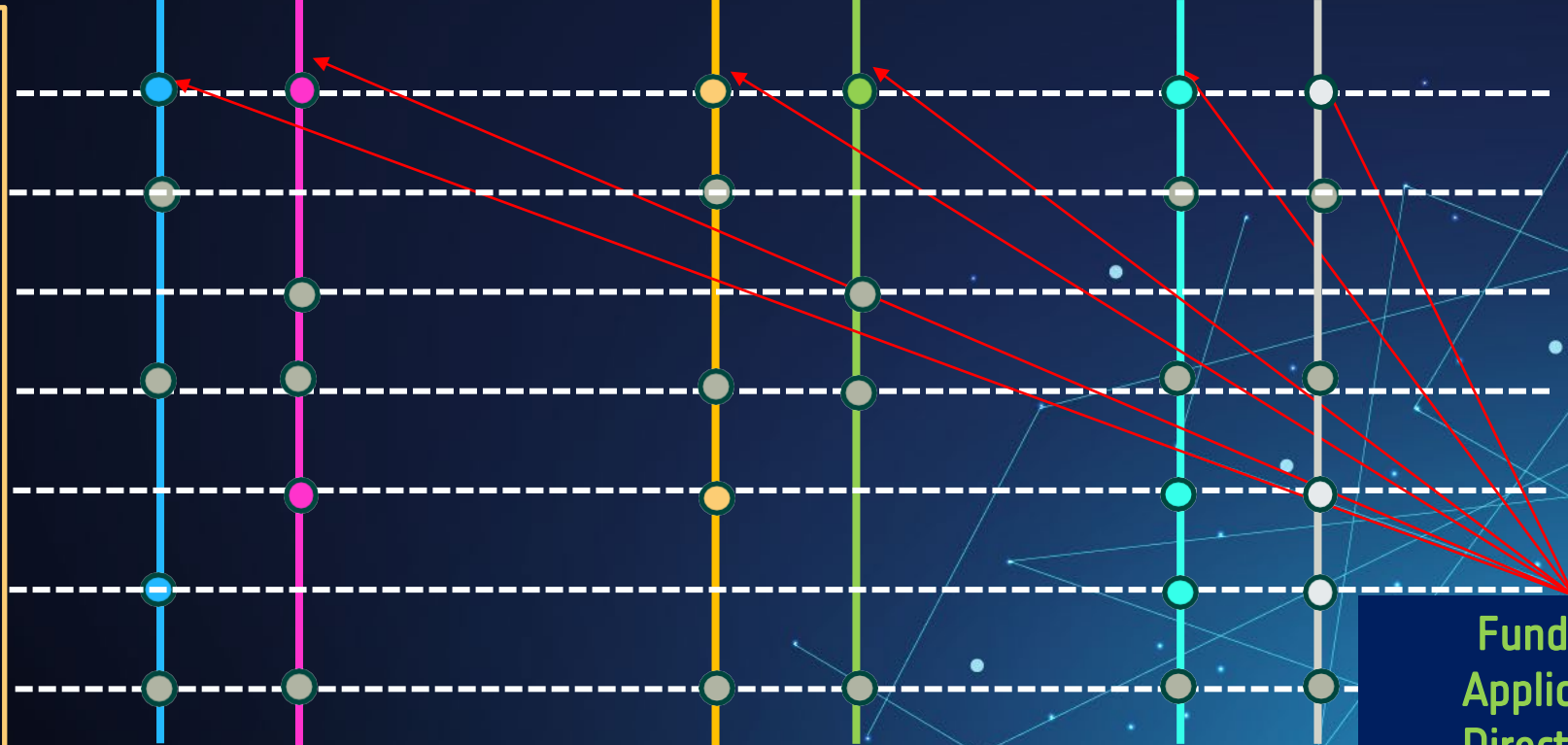

Funded by  
Application  
Directorates



# M-IND Equipment & Modules (mid-size sats for LEO constellations)



## Platform Equipment & Modules



Data Handling

- 01a- Platform DH Unit [OBC, RTU, GNSS, Security, ...]
- 01b- Payload DH Unit [ICU, DPU, Routing, SSMM, ...]
- 01c- Modules - for Units above - preferably ADHA compatible

Mind the Vertically integrated context!



Security

02 - Stand-alone Crypto Unit [for TT&C and Institutional market]



AACS

- 03a- RW [insufficient volume in ESA-MS]
- 03b- CMG [insufficient volume]
- 03c- Other [communalize Interfaces, demisable wheels]

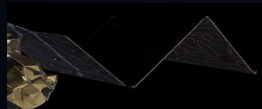

Power

- 04a- Solar Generators [integrating ESA-MS solar cells]
- 04b- Battery Units [integrating ESA-MS batteries, passivation]
- 04c - PCDU [full unit]
- 04d- Modules PCDU [preferably APA compatible, better with WBG/GaN]

Sovereignty



Comms / TT&C

- 05a -TT&C Transponders [insufficient volume i
- 05b- Payload Data Tx [insufficient volume]
- 05c- Optical Heads ISL [TBC insufficient volume – ARTES ScyLight driven]
- 05d - RF ISL for TTC [insufficient volume]

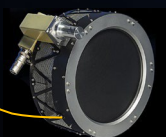

Propulsion

- 06a- e-Prop Sys [full plug-and-play]
- 06b,c,d,e - Modules [PPU, Thrusters, Tanks [demisable], valves/regulators]



Optical & RF Techno. EO Payload Modules

- 08a - Camera modules [FPA integration]
- 08b -Imaging optical sub-sys [mirrors, telescopes]
- 08c -RF Modules Radiating Elem + SSPA/LNA amplify. [with WBG / GaN]
- 08d- Modules of P/L DH Units : "High speed RF, mixed signal and digital PCBs" + Backend Digital



# 1.7 Eligibility of M-IND RFI Outline Proposals

## 4 Criteria for Eligibility:

- Crit.1: Application & potential users
- Crit.2: Technical Objectives and REQ. for mid-size LEO sats
- Crit.3: Roadmap, technical steps
- Crit.4: Management & cost

Points specified in the GSTP BUILDING BLOCKS framework:

- o Clear indication of the application and potential users of the technology.
- o Clear and credible technical objectives, key requirements, technical steps and risks in the activity.
- o Clarity of management approach and the adequacy of the proposed costs with the work to be performed together with the:
- o M-IND priorities, incl. European technology sovereignty, benefitting many stakeholders and market demand
- o Credibility of the proposed Roadmap with the “full end-to-end cost and time phased-overview”

### Priorities for M-IND activities :

- **Very high:** not available in Europe / Europeanisation
- **High:** adaptation benefits several integrators
- **Medium:** adaptation benefits one (vertical integration)
- **Low:** market saturated or with low demand

Phase Nb	Title	TRL		MRL		Months	Budget (k€)	
		Start	Target	Start	Target		ESA price	Full cost
1	Consolidation - Feasibility	4+				4	GSTP	Elem.1
2	Finalise Product		6 / 7			12	TBD	
3	Industrialisation				7	10	Option	al Prog.

# 1.7 Criteria importance for the RFI

## COLOUR LEGEND

- TOP PRIORITY for the RFI
- to be further developed if the activity is supported / enters into consolidation.

To accelerate ESA's feedback:

- please copy [REQ-Nb] into the GSTP Template

### Crit.1: Application & potential users

- Product overview [REQ-1 to REQ-2]
- Fits Mid-size LEO sat [REQ-3]
- Application [REQ-4]
- Potential users [REQ-5 to REQ-7]

### Crit. 2: Technical objectives and requirements

- Technical overview [REQ-8]
- Fits M-IND Equipment / Module [REQ-9]
- Environmental [REQ-10 & REQ-11]
- Common Interfaces [REQ-12]
- European Technology [REQ-13 & REQ-14]
- Sustainability [REQ-15 & REQ-16]
- Industrialisation [REQ-17 to REQ-19]
- Prevent Duplications [REQ-20 & REQ-21]
- Technical feasibility [REQ-30 to REQ-32]

### Crit. 3: Roadmap, technical steps and risks

- TRL & MRL Philosophy [REQ-22 to REQ-25]
- Engineering Approach [REQ-26 to REQ-29]
- Programmatic Approach [REQ-33 to REQ-35]

### Crit. 4: Management & cost

- Background [REQ-36 to REQ-37]
- Facilities [REQ-38]
- Planning [REQ-39 to REQ-42]
- Cost [REQ-43 to REQ-46]

High Level feedback (1-2 pages) will be based on this criteria

If recommended for next step, TBC which more details to help full-propos

# Checklist- Paragraph 1– Technical and Application

To accelerate ESA's feedback – please copy the [REQ-Nb] into the GSTP Template

## 4 Criteria for consideration:

- Crit.1: Application & potential users
- Crit.2: Technical Objectives and REQ. for mid-size LEO sats
- Crit.3: Roadmap, technical steps
- Crit.4: Management & cost

## 1.1 APPLICATIONS of the DEVELOPMENT

REQ-1 General product description, targeted missions and markets  
REQ-2 Product (category selection)

Crit.1

REQ-3 Product (compliance to mid-size System)  
REQ-4 Application (product relevance to LEO application domains)

REQ-5 Product (development purpose)  
REQ-6 Product (position wrt competition)

REQ-7 Product (availability - i.e. for vertical integration or open market)

## 1.2 TECHNICAL OBJECTIVES and REQUIREMENTS

REQ-8 Technical objectives, goals/thresholds, verification approach  
REQ-9 Relevance (type of equipment and/or P/L in mid-size LEO sats)

REQ-10 Environmental (compliance matrix)  
REQ-11 Environmental (radiation challenges)

REQ-12 Common interfaces (current and potential adoption)

REQ-13 European technology (current)

Crit.2

REQ-14 European technology (future)

REQ-15 Sustainability (space debris mitigation)

REQ-16 Sustainability (ecodesign)

REQ-17 Industrialisation (company approach)

REQ-18 Industrialisation (drivers and challenges)

REQ-19 Industrialisation (lead times)

REQ-20 Synergies with existing ESA, EC, or national activities

REQ-21 Duplications (potential overlaps)

## 1.3 TECHNOLOGY READINESS and MODEL PHILOSOPHY

Crit.3

REQ-22 TRL and model philosophy

REQ-23 TRL (initial and target)

REQ-24 TRL (product adaptations at module and/or sub-Sys level)

REQ-25 MRL (initial and target)

## 1.4 TECHNICAL STEPS and IMPLEMENTATION of the ENGINEERING APPROACH

REQ-26 Baseline design approach and trade-offs

REQ-27 Implementation (technical & management)

Crit.3

REQ-28 Implementation (deliverables)

REQ-29 Implementation (milestones)

## 1.5 TECHNICAL FEASIBILITY, TECHNOLOGY CHALLENGES and DEVELOPMENT RISKS

Crit.2

REQ-30 Feasibility assessment to reach the functional performance

REQ-31 M-IND Objectives (compliance matrix)

REQ-32 M-IND Objectives (technical challenges and risks)

## 1.6 TECHNICAL IMPLEMENTATION /PROGRAMME of WORK

Crit.3

REQ-33 Implementation (workflow logic, reviews, critical paths)

REQ-34 Implementation (schedule/timeline)

REQ-35 Implementation (deliverables/outputs)

# Checklist – Paragraph 2 & 3 – Management & Financial

## 4 Criteria for consideration:

- Crit.4: Management & cost

To accelerate ESA's feedback – please copy the [REQ-Nb] into the GSTP Template

### 2.1 BACKGROUND of COMPANY(ies)

- REQ-36 Background (summary)
- REQ-37 Background (contractors, sub-contractors, ext services)

### 2.2 FACILITIES

- REQ-38 Production (facilities)

### 2.3 PLANNING

- REQ-39 Schedule (Gantt chart) - optional
- REQ-40 Schedule (Long lead times) - optional

### 2.4 LIST of DELIVERIES

- REQ-41 Phase 1 (deliverables)
- REQ-42 Phase n (n+1) (deliverables) - not applicable

### 3.1 PRICE QUOTATION for the CONTRACT

- REQ-43 Cost (price quotation for a contract)
- REQ-44 Cost (price breakdown per country - as per table)

### 3.2 DETAILED PRICE BREAKDOWN

- REQ-45 Cost (detailed price breakdown) - not applicable

### 3.3 COST to COMPLETION

- REQ-46 Cost (price breakdown per phase - as per table)

Ph. Nb	Title	TRL		MRL		Duration (months)	Budget (k€)	
		Start	Target	Start	Target		ESA price	Full cost
1	Consolidation - Feasibility	4+				4		
2	Finalise Product		6 / 7			12		
3	Industrialisation				7	10		
	Other optional - if justified							

Ph. Nb	Title	Duration months	Country ISO code	Budget (k€)		
				ESA k€	ESA %	Company k€
1	Consolidation - Feasibility	4	#1		%	
			#2		%	
			Sub-total			
2	Finalise Product	12	#1		%	
			#3		%	
			Sub-total			
3	Industrialisation	10	#1		%	
			#4		%	
			Sub-total		%	
			TOTAL		%	

# 1.7 Feedback

## 4 Criteria – summary feedback (1-2 pages TBC)

- Crit.1: Application & potential users
- Crit.2: Technical Objectives and REQ. for mid-size LEO sats
- Crit.3: Roadmap, technical steps
- Crit.4: Management & cost

To the Industrial supplier shortly (always)

To the National Delegation (specially in case of positive feedback & fitting to the M-IND initiative)

- a summary feedback to determine the following steps.
- different **National Delegations** might apply **different procedures**
  - some may immediately go ahead for Ph.1
  - some may want to combine phases
  - **some may want pitches before any commitment**

In case of endorsement by the Member / Associated State (MS / AS):

- **Letters of Support** may be prepared by the National Delegation (below 1 M€, **no need for IPC with all Delegations**)
- The **Outline Proposal** would need to be converted into **full proposal** (with PSS, and address the feedback)

Accelerated procurement for the **following phases**

- Timely **approval by IPC** (when above the 1 M€ IPC threshold + assuming good progress of on-going phase)
- **CCN** (preferably) – i.e. cover page + agreements in the earlier phase + PSS

# 1.8 Industrialisation - to be consolidated (REQ. 17-19)

- Current and Target **MRL**
- A **capacity-building plan** for the product on the same manufacturing line (reaching **MRL 7**).
  - Current and Target **Production rate**: Quantities, Cadence, Lead Time
  - Key **milestones**
  - Associated **costs**
  - **Target price** of the **recurring product** and related assumptions (e.g. minimum order quantity, etc.).
  - Use of **Manufacturing standards**
- **Product Assurance/Quality Assurance approach** for the envisaged product
  - **approach** to achieve **TRL=7** and associated **MRL**, if not yet reached
  - different **quality** aspects (e.g. quality control, monitoring of non-conformities)
  - **RAMS approach** leveraging robustness/redundancies at constellation level wrt at satellite level
  - **approach** wrt **ECSS Requirements** or TBD **alternative Commercial Requirements**
  - **approach** for the use of **COTS**
  - **approach** for Risk Reduction, Manufacturing Maturation, Obsolescence, Spares Provision, etc. for **industrial/serialisation**
- **gaps** needed to achieve the objectives and “**pain points**” regarding industrialization
- **interest** for certification by third parties that could help your product – see EQSP

# 1.8 Prevent Duplications

1. GSTP Compendia
2. GSTP Workplan (Propulsion & Security)
3. SMART-IND (next slide)
4. Complementary Space Debris Mitigation activities



# Submitting a Response to the M-IND RFI

- Access the Industrialisation / Serialisation Support Campaign for the M-IND RFI via OSIP: [Open Space Innovation Platform - OSIP - Campaign: INDustrialisation / Serialisation Support Campaign](#)
- Note: the Industrialisation / Serialisation Support Campaign **hosts 2 initiatives**:
  - SMART-IND!: campaign just closed and
  - **M-IND RFI: Campaign open until 15 May 2026**

- Click **Submit Your Idea**
- Select **M-IND** as the type
- Follow the instructions



The screenshot shows the landing page for the 'INDustrialisation / Serialisation Support Campaign'. The page features a dark blue background with a satellite and rocket illustration. The main heading is 'INDustrialisation / Serialisation Support Campaign'. Below it, the text reads 'Supporting the expansion of industrial capacities and capabilities in the European Space Sector'. A profile picture of Dietmar Pilz, Director of Technology, Engineering and Quality, is shown. A prominent blue button labeled 'Submit Your Idea' is highlighted with a yellow arrow from the left. The page also includes the text 'We TEC you' and 'to the FUTURE'. On the right side, there are navigation options for 'Discu' and 'Attach'.

Submit Your Idea

TYPE \*

The Campaign is open for ideas falling under the scope of the INDustrialisation/ Serialisation Support Campaign.

M-IND

M-IND

SMART-IND

Until 15<sup>th</sup> May

Until 31<sup>st</sup> March

- Products in mid-size LEO satellites that **do NOT** require new design
- can go directly into industrialisation and serialisation
  - should be submitted **directly** to SMART-IND

## COMPetitiveness & INDustrialisation

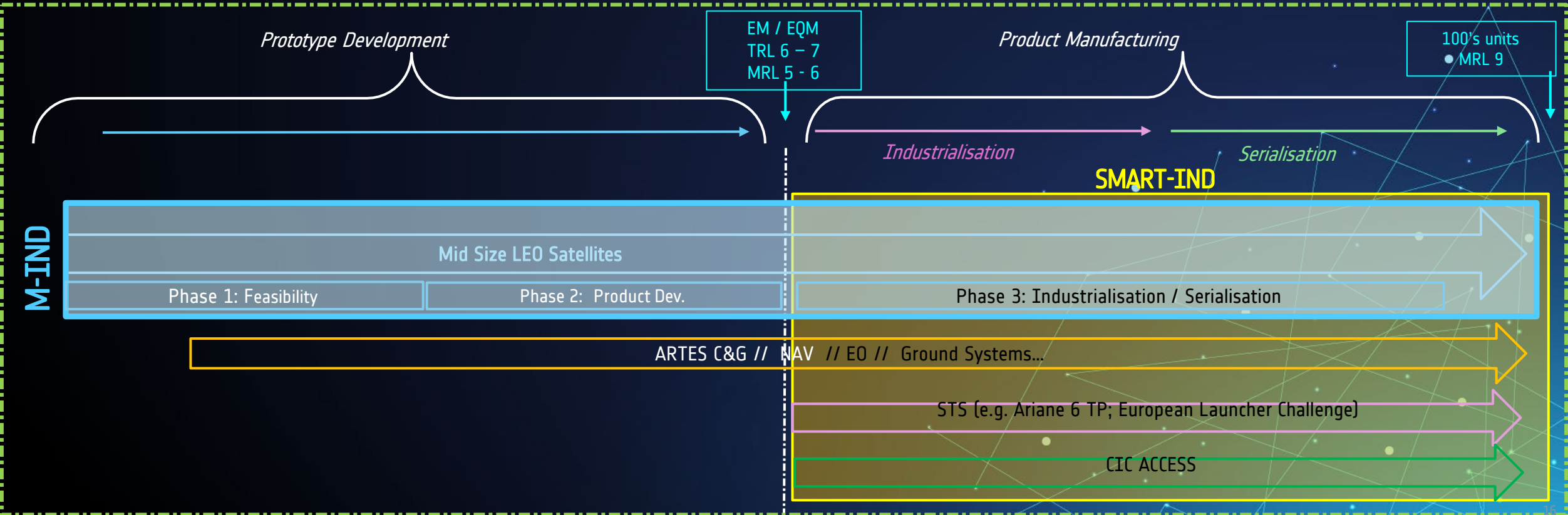

# M-IND RFI in OSIP

RFI Webinar Q&A on 10<sup>th</sup> April @ [indico.esa.int](https://indico.esa.int)

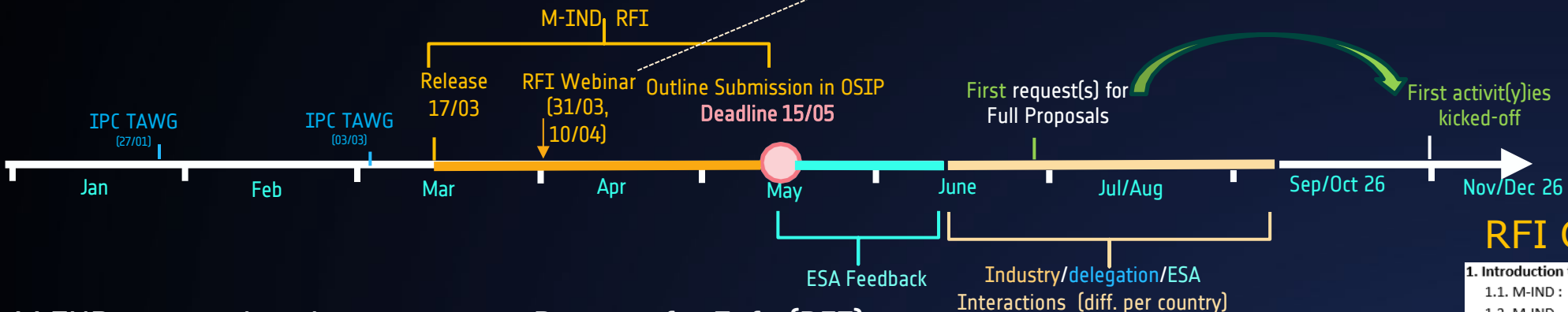

M-IND proposals – in response to Request for Info (RFI):

- using the standard **GSTP Building Block outline template** ([link](#))
- and the **M-IND Checklist**

INDustrialisation / Serialisation Support Campaign

Submit Your Idea

considering (full) phased-approach – **example** → 2028 target

Phase Nb	Title	TRL		MRL		Months	Budget (k€)	
		Start	Target	Start	Target		ESA price	Full cost
1	Consolidation - Feasibility	4+				4	GSTP	Elem.1
2	Finalise Product		6 / 7			12	TBD	
3	Industrialisation			7		10	Option	al Prog.

## RFI Guidelines (*esastar*)

1. Introduction to M-IND and this M-IND RFI.....
  - 1.1. M-IND : Mid-size LEO satellite INDUSTRIALISATION.....
  - 1.2. M-IND – RFI (not contractually binding).....
  - 1.3. Phased-approach Roadmap in the M-IND RFI Outline Proposals.....
  - 1.4. Scope of the M-IND RFI.....
  - 1.5. For whom is this RFI?.....
  - 1.6. Priorities for M-IND activities – affecting the feedback.....
  - 1.7. Eligibility and feedback.....
  - 1.8. Timeliness - 2028.....
  - 1.9. Document breakdown.....
2. Applicable and Reference documents.....
  - 2.1. Applicable Documents.....
  - 2.2. Reference Documents.....
  - 2.3. Acronyms.....
3. Checklist for the M-IND RFI.....
  - 3.1. Paragraph 1 - Technical and Application part of [AD-1] :.....
  - 3.2. Paragraph 2 - Management Part:.....
  - 3.3. Paragraph 3 - Financial Part:.....
4. Preferred Equipment & Modules for Mid-size sats for LEO constellations.....
  - 4.1. Platform Sub-systems.....
  - 4.2. Payload Modules s for mid-size LEO satellites.....
5. High Level System Requirements / Boundaries.....
  - 5.1. System Level Requirements / Boundaries.....
  - 5.2. Equipment / Module Level Requirements.....
  - 5.3. Payload Modules requirements.....
  - 5.4. Common Interfaces and High Level Reference Architecture.....
  - 5.5. Sovereignty.....
  - 5.6. Sustainability Requirements for ESA missions.....
  - 5.7. Industrialisation Requirements.....
  - 5.8. Prevent Duplications.....
  - 5.9. Product Deliverables by the end of the Phase-1 Consolidation.....
6. Conclusion.....



## GENERAL

Q1: Is it possible to **dialogue with ESA experts** before submitting the RFI ?

- Yes, it's only an RFI (not an ITT with focal Contract Officers)

Q2: Will the deadline of the RFI (15-May) be extended ?

- No, otherwise it would not be possible to provide feedback before the summer break
- It's only an RFI – in case of positive feedback & support, there will be more time to improve the full proposal

## CONSOLIDATION Ph.-1:

Q3: activities with Building Block limited by the 1 M€ budget cap ?

- Budget needs to be **commensurate with work**
- Short duration without hardware probably implies < 1 M€
- Building Blocks below 1 M€ only need the support by your Delegation (i.e. no need to go to IPC with all others)
- It is an RFI (not an ITT)
  - but if accepted by the Delegation to go **beyond 1 M€**, then we need to go to **IPC with all Member States**

Q4: Is the duration of Ph.1 limited to 4 months (pg. 5 example) or 6 months (pg. 15 example)

- Duration needs to make **technical / programmatic sense**(and justifiable)
- these are only **indicative examples** (not a max. duration) – the inconsistency **4 vs 6 months is a typo**
- competitiveness implies fast into the market



# Q & A (3)

## **FOLLOWING PHASES**

- **Q8: What is the co-funding level expected ?**
  - This will depend on the exact work (phase), and possibly also on the Delegation requirements
  - The GSTP Elem.2 (Make) gives a possible overview ([link for details](#))
- **Q9 – How will IPR be treated ?**
  - At this RFI stage, there is no question about IPR,
  - but it will need to be defined for the full proposal and consolidation phase (it will also depend on the target market)
- **Q10: What can be covered under Industrialisation ?**
  - Capital investments (e.g. building) are excluded - but OK if identified
    - ESA commercialisation can advise for complementary means (e.g. loans via EIB)
  - Machinery - it depends (needs to be related to the product, not just capital investment) - co-funding approach expected
  - Manpower effort to setup the plans can be included
  - All this might need additional iterations in case of requesting full-proposal / or when activating CCNs

TRL of development		Univ. and Institutions*	SME (up to)	Non-SME (up to)
Min	Max			
3	6	100%	80%	75%
6	8	100%	80%	50%

# Q & A (4)

## HOW TO HELP ESA ACCELERATE THE FEEDBACK

- Q11 – Use of the GSTP Building Blocks and REQ-1 / REQ-46 of the M-IND RFI (section -3 Checklist) ?
  - The use of the GSTP Template ([link](#)) is mandatory
  - Strongly recommended you **copy the [REQ-1], [REQ-2], ... labels** into your answers using the GSTP Template
    - this will accelerate the “feedback” to be provided by ESA within June by multiple experts in different disciplines

## SPECIFIC QUESTIONS

- Q12– We’re bidding for similar activities, but until we know if we are selected, it’s difficult to say if it is a duplication.
  - REQ-20 Synergies with existing ESA, EC, or national activities
  - REQ-21 Duplications (potential overlaps)
- the status of activities evolve in time the M-IND RFI offers a **complementary Industry-driven** approach wrt the **ESA-driven** approach (e.g. in GSTP Compendium, where the SoW is written by ESA)
  - Important to state that **complementarity**, and perhaps to define **scenarios** (e.g. selected or not in other bids)
    - If the ESA-driven activities and the M-IND RFI proposal are identical, that will appear in the feedback
  - In case of positive feedback & support, the status should be updated accordingly (e.g. for the full proposal)