

FROM A CUSTOMIZED AOCS SCOE TO A MULTIPURPOSE EGSE ARCHITECTURE

M.Alberti⁽¹⁾, M.Bossi⁽²⁾, F.Brega⁽³⁾, D.Biz⁽⁴⁾

TEMIS s.r.l., Via G. Donizetti 20 20011 Corbetta(MI), Italy

⁽¹⁾ Email: marco.alberti@temissrl.com

⁽²⁾ Email: marco.bossi@temissrl.com

⁽³⁾ Email: federico.brega@temissrl.com

⁽⁴⁾ Email: diego.biz@temissrl.com

ABSTRACT

The AOCS SCOE is one of the most complex types of EGSE which can be built for a satellite. It requires conjugating and coordinating a large amount of heterogenic interfaces together with complex and precise real time simulation environment.

Modularity gives the possibility to maximize reuse of components (both HW and SW), to reduce test effort at system levels by mean of subsystem and unit tests, to enforce system flexibility and scalability

Galileo[4] AOCS SCOE has been the first effort in this direction and it drove the development of a general AOCS SCOEs, based on a semi-modular architecture, with a strong reuse of models and custom plug-in modules

A fully modular general EGSE architecture has then been derived, where each plug-in module is in charge to perform the complete acquisition/stimulation chain from UUT to EGSE, including AD conversion.

MTG IRS[6] and Thermal EGSEs developed for OHB Munich have been realized following the fully modular idea, leveraging the experience gained with Galileo. In this case it has been possible to share the same building blocks between IRS and Thermal EGSE allowing also the end user to re-arrange the I/F type and numbers during the project without impacting the global architecture

1. INTRODUCTION

The Aerospace field typically requires highly personalized EGSE that, together with a tight schedule, does not allow a rationalization of the project, and it forces the supplier creating always “ad hoc” products, sacrificing the engineering activities, and reducing the chances of re-use of the system or its parts.

The goal TEMIS is trying to reach is the maximization of the modularity keeping at the same time high development potential to meet future requirements or changes in reference technologies.

2. GALILEO AOCS SCOE

The Galileo AOCS SCOE was in charge to support the verification phase of the GALILEO satellite AOCS subsystem, closing virtually the loop between sensors and actuators, simulating the dynamic and the

kinematics of the spacecraft, taking into account the control commands together with the environmental and internal disturbances. The following figure shows the HIL (Hardware In the Loop) architecture used from the customer during the test campaign

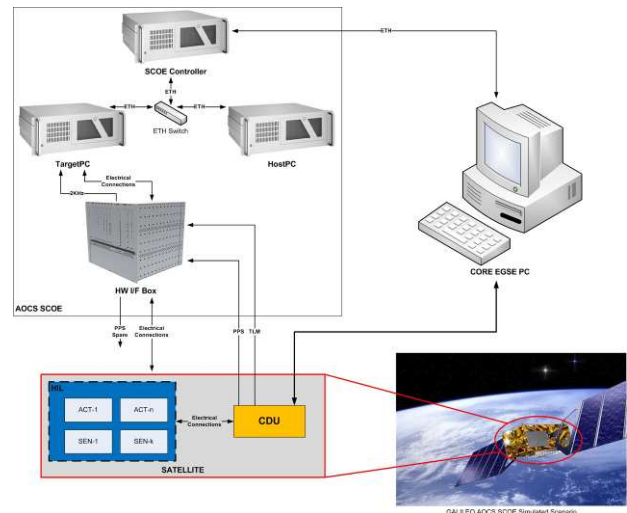

Figure 2-1 HIL Overview

The main function of the SCOE Controller was to manage the Simulation presenting a local MMI (Man Machine Interface) & connecting to CCS (Central Check-out System) for the EGSE remote control capabilities

The HOST PC was hosting the development environment (Simulink) and a local 3D visualization of the satellite w.r.t. the main celestial bodies

The Target PC is the real-time machine and contains the COTS (Commercial Off The Shelf) Board needed to complete the acquisition/stimulation chain

HW I/F Box was the HW core of the SCOE and it was in charge of:

- Conditioning of the I/O signals
- Triggering the Target PC
- Hosting custom FPGAs
- Galvanically isolating the SCOE with respect to the s/c (spacecraft).
- Protect the s/c with over current, over voltage

- and fuse
- Physically disconnect to SCOE from the s/c by means of switches
- Routing internally the signals for an automatic self test

The figure below is a rendering of the HW I/F box front. It can be seen that functional modules are vertical mounted, with monitoring LEDs on the front panels.



Figure 2-2 HW I/F box front

The commercial boards have been placed in the Target PC and then connected to the HW I/F that is in charge to condition the signals in order to be compliant with the sensors and actuators ICDs.

The following figure shows that in the upper side are placed the connectors to plug the harness with the Target PC, while in the bottom side are placed the connectors to plug the harness directed to s/c.



Figure 2-3 HW I/F box Rear

The architecture is called semi-modular because some of the plug-in modules are in charge to perform directly

the complete acquisition/stimulation chain SCOE-UUT (Unit Under Test) and they are connected to the Target PC via serial line (this is the case for instance of Earth Sensor module, Gyro module, Reaction Wheel module). On the contrary some other plug-in modules are in charge to simply condition the I/O signals and the acquisition is then done in the Target PC by the COTS board.

For the Galileo AOCs SCOE one HW/IF box was enough to stimulate all the UUT I/Fs and all the equipments was mounted in a single rack shelter.

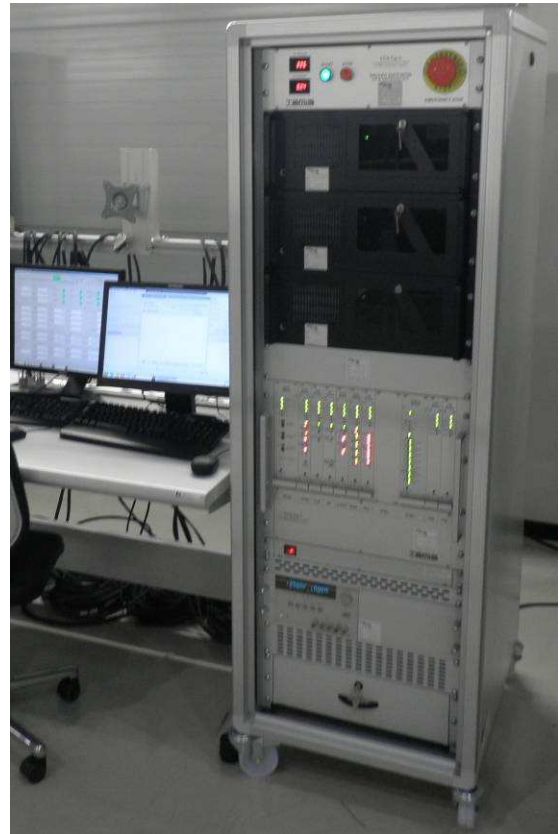

Figure 2-4 Galileo AOCs SCOE

3. GENERAL TELOCOM AOCs SCOE

After positive working experience with the four Galileo AOCs SCOEs delivered to OHB premises, our customer decide to order a General AOCs SCOE to be used for their TELECOM[5] satellite projects, derived from the Small Geo platform.

In this particular case, the modular architecture gave the possibility to compress the schedule (1 year w.r.t 2 year for Galileo) maximizing modules reuse (about 70% of simulator modules, 100% of I/F protocol code, and 30% of functional modules are identical).

It worth to mention that this has been possible even for a system which has about three times the number of I/Fs of Galileo SCOE.

To cope with targeted price and schedule it has been

decided not to optimize the architecture for the TLC SCOE but it's has been preferred to realize it using the Galileo building blocks.

As can be seen in Figure 3-1 thanks to the system modularity the number of I/O lines has been triplicated simply adding other two HW I/F boxes in order to expand the SCOE capabilities.



Figure 3-1 TLC AOCs SCOE

Where the similarities between GALILEO and TLC platform were clear, the plug-in modules already developed for Galileo AOCs SCOE has been used in the TLC SCOE like they were COTS product.

Where the sensor/actuator plug-in module was not present in the previous project new boards have been design and produced, always following the architecture specifications hence increasing also the number of COTS product now available in TEMIS.

The following plug-in modules can be considered as COTS building blocks:

Plug-in	Description
Earth Sensor	Stimulate an Earth sensor in the loop, simulating the earth –moon-sun detection
Fine Sun Sensor	Stimulate a FSS in the loop

Plug-in	Description
Coarse sun sensor	Simulate the very low noise solar cells output
High Precision Gyro	Stimulate in the loop an high precision gyro with simulation data
Reaction Control Thruster	Acquisition of the fast open/close activation signals of the RCT FCV and on off status of Latch valves
Liquid Apogee Engine	Acquisition of the fast open/close activation signals of the LAE FCV and on off status of Latch valves
SADM	Acquisition of angular encoder signals in the loop
Reaction Wheel	Acquire the signals of Reaction wheel in the loop (Tacho & discrete) providing a very accurate speed measurement
PPS	Catch synchronism with PPS via a PLL. Handles input signal disruption propagating the current frequency, and handles two (main and redundant) inputs

Table 3-1 AOCs plug-in Library

4. FULL MODULAR GENERAL PORPOUSE EGSE

The AOCs SCOEs usually have stringent requirements on SW task execution being involved in tests with HW and SW in the loop, hence a real-time operative system has been chosen and fast acquisition boards were necessary, with very small communication latency.

This was the rationale behind the aforementioned Semi-modular system where part of the acquisition is done from the plug-in modules and part directly in the target PC under a real-time system, leveraging the low latency of the PCI bus

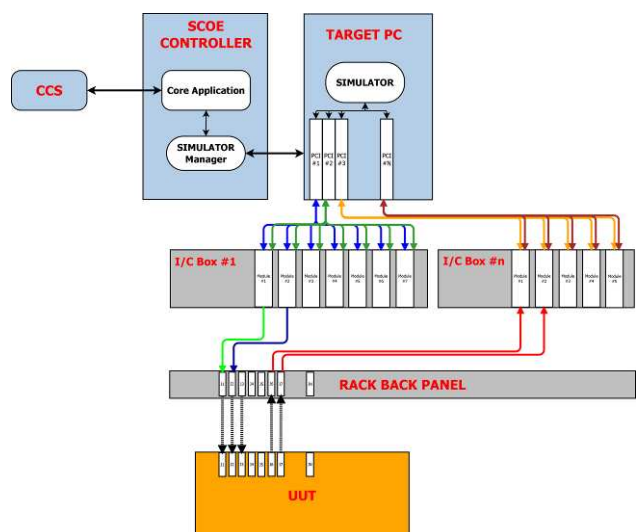

Figure 4-1 Semi-Modular

There are other applications where it is not so important to have a low latency and time deterministic update frequency of the HW. For this kind of application, a different EGSE architecture has been thought delegating all the computation tasks on distributed and synchronized plug-in modules, leaving to the host PC only the task to manage the simulation and store the already acquired and time tagged data.

The Full Modular EGSE have then been developed, based on the integration of plug-in modules (FPGAs) working in parallel and independently like they were many SCOE's inside the same rack but synchronized with an external time source.

Each plug-in module, managing standard ECSS I/F like ASM, BSM, HPC etc, is in charge to perform the complete acquisition/stimulation chain from UUT to EGSE, including AD conversion

MTG IRS and Thermal EGSEs developed for OHB Munich have been thought to be fully modular. In this case it has been possible to share the same building blocks between IRS and Thermal EGSE allowing also the end user to re-arrange the I/F type and numbers during the project without impacting the global architecture.

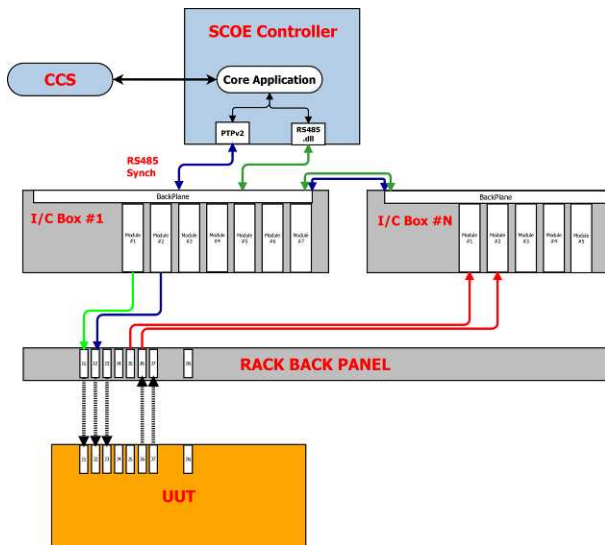

Figure 4-2 Full-Modular

As it can be seen in the previous figures the full modular EGSE has a simpler layout:

- the target PC is not more necessary
- the internal cabling is trivial, only a communication bus (e.g. RS485) and synch signals
- Only one SW drivers is needed, to manage the communication bus

The figure below shows the TM/TC box that can accommodate all the boards dedicated to the discrete

signals acquisition/generation ECSS compliant [1].



Figure 4-3 Discrete TM/TC Box

The box lodges up to 18 plug-in modules that can be freely chosen from the following table, given the customer the possibility to easy configure its own system:

Plug-in	Description
TSM1	18: NTC thermistor simultaneously acquisition
TSM2	4: PT1000 thermistor simultaneously acquisition
HPC	8: High Power Command simultaneously generation
BSM	10 : Bi-Level simultaneously acquisition
ASM	8 : Analogical Signal simultaneously acquisition

Table 4-1 TM/TC plug-in modules

With the same philosophy of the TM/TC box TEMIS has realized also a LCL (latch current limiter) Box and a HTR (Heater) Box.

The LCL modules are in charge to provide power to UUT implementing the same characteristics of the flight Power Distribution Unit.

The HTR modules are used to drive heater during the thermal test campaign, allowing performing a thermal control loop by means of TSM acquisition and PWM (power width modulation) of the HTR lines.



Figure 4-4 LCL Box

The Boxes and the plug-in can be combined in the EGSE as the customer want, they have only to share the same RS485 Bus.

Currently the max number of plug-in modules acceptable on the same bus is 50 (fifty) with 1Hz telemetry rate.

5. CONCLUSION

The evolution and reutilization of an AOCS SCOE based on a semi-modular architecture has been presented. The semi-modular layout benefits having reusable building blocks and, at the same time, running the simulator under a real time environment.

In order to reduce the costs and to increase the modularity of the system, a full-modular architecture has then been presented based on up to 50 independent, but synchronized units running in parallel sharing the same RS485 bus. The full modular system has the advantage to be simpler and easily scalable when real-time constraints are not required.

The next challenge TEMIS is going to face is to realize a real-time full modular EGSE enhancing the bus layout moving from a deterministic but slow bus like the RS485 (with proprietary protocol) implementing the data exchange by means of high speed link (e.g. optic fibber or Ethercat bus).

6. REFERENCES

1. ECSS-E-ST-50-14C: *Spacecraft Discrete Interfaces*
2. ECSS-E-ST-20-07: *Electromagnetic compatibility*
3. <https://www.ohb-system.de/small-geo-luxor-english.html>
4. https://www.ohb-system.de/galileo_engl.html
5. <https://www.ohb-system.de/mtg-330.html>